

Installation Instructions

CD200D Digital Ignition System

Form CD200D II 9-10



1.0 DESCRIPTION

- 1.1 This manual provides installation and operating instructions for the Altronic CD200D ignition system. It is recommended that the user read this manual in its entirety before commencing operations.
- 1.2 The Altronic CD200D ignition system consists of these basic components:
 - CD200D Unit - 791090-x (see FIG. 1)
 - Magnetic Pickup Sensor or Hall-effect pickup (one per system)
 - Input Harness (one per system, specific to pickup type)
 - Output Harness (one per system)
 - Ignition coils (one per cylinder)
- 1.3 The system requires a battery or a suitable power supply with a nominal 12 Vdc or 24 Vdc (see FIG. 2). The CD200D unit steps up the DC supply voltage to charge an energy storage capacitor and contains a microprocessor and solid-state switching devices to release the stored energy to the ignition coils in programmed, timed sequence according to the application. Holes (one per cylinder) in a special timing disc signal the position of the engine crankshaft to the electronic circuitry in the CD200D unit. One additional hole trails after the last cylinder hole; this is the index signal that another revolution has started. An Altronic manufactured magnet disc should be used when employing a Hall-effect pickup. Ignition timing may be varied by means of a manual switch, an analog timing signal and/or engine RPM.
- 1.4 The CD200D system can operate as a single-firing or double-firing (firing on exhaust stroke) system up to sixteen (16) cylinders. These instructions detail 8-, 12-, and 16-cylinder, single-firing applications using CD200D units 791090-8, 791090-12, 791090-16.
- 1.5 As shipped from the factory, the CD200D is in the auto-detect mode and is set up for a trigger disc running at camshaft speed (see SECTION 9.5). The setup is programmable by the use of the PC compatible CD200D terminal program (see FIG. 9) provided on a CD delivered with the unit. The programming of the unit is done via the RS-485 Modbus compatible communications port.

WARNING: DEVIATION FROM THESE INSTRUCTIONS MAY LEAD TO IMPROPER OPERATION OF THE MACHINE WHICH COULD CAUSE PERSONAL INJURY TO OPERATORS OR OTHER NEARBY PERSONNEL.

NOTE: If possible, keep the original shipping container. If future transportation or storage is necessary, this container will provide the optimum protection.

2.0 CD200D UNIT

- 2.1 Select a location for the CD200D unit that will be at least 24 inches (600mm) away from the ignition coils and spark plug leads. In addition, the mounting location must be relatively cool, preferably one benefitting from the engine fan stream (if any); the outside case temperature of the CD200D unit should not exceed 185°F. (85°C.) in continuous operation.
- 2.2 Secure the CD200D unit to a suitable mounting bracket with four ¼-inch (6 mm) screws. Refer to FIG. 1 for CD200D unit dimensions.

3.0 PICKUP SENSOR – CAMSHAFT DISC

- 3.1 **MAGNETIC Pickup** – A disc with the appropriate hole pattern must be prepared for mounting at CAMSHAFT speed. The disc must be of magnetic material and 4.0" (100mm) diameter or larger. FIG. 3 details the hole spacing depending on the number of engine cylinders. Note the direction of rotation of the disc. The angular spacing is extremely important as this establishes the basic timing accuracy of the system.
- 3.2 Locate a suitable mounting position for the pickup sensor in order to sense the holes in the rotating disc. Secure the pickup to a rigid bracket or surface. See FIG. 3 for the dimensions of the ¾"-16 pickup sensors.

NOTE: Some MAN engines have a 12 mm thread port; use Altronic pickup 791041-3.

- 3.3 Set the engine with no. 1 cylinder in the most advanced timing position. Noting the direction of rotation, set the drilled disc opposite the pickup in the position shown in FIG. 3. Some 12- and 16-cylinder engines may require line up on a different cylinder, typically the second cylinder in the firing order.
- 3.4 Adjust the tightening nut holding the pickup sensor to maintain an air gap as specified below:
- For 3/4" magnetic pickups 791015-1 and 791016-2, the gap shall be set to .020" ± .005" (0.50mm ± 0.12mm).
 - For magnetic pickups 791035-2 and 791041-3 (12mm thread), the gap shall be set to .014" ± .004" (0.35mm ± 0.10mm).

The center of the pickup face must line up with the center of each drilled hole as the disc rotates.

- 3.5 Plug the 2-pin pickup connector fully into the mating connector of the CD200D wiring harness.
- 3.6 ALTERNATIVE HALL EFFECT Pickup AND MAGNET DISC – On 4-cycle engines, the disc mounts to the camshaft or other shaft operating at one-half engine speed. On 2-cycle engines, the disc mounts to the engine crankshaft.
- 3.7 Set the engine with no. 1 cylinder 2.0 crankshaft degrees, 4-cycle or 1.0 degree, 2-cycle ahead of the most advanced desired timing point on the compression stroke. This is the point where the Hall-effect pickup must line-up with the edge of the magnet next to the "x" on the O.D. of the disc. When mounting the magnet disc, be sure to observe the rotation indication marked on the disc.
- 3.8 Mount the Hall-effect pickup sensor, FIG. 4, securely to a rigid bracket or surface to maintain an air gap not exceeding .040" (1.0mm). The center of the pickup face must also line up with the center of the disc as it rotates.
- 3.9 Plug the cable for the pickup into the 6-pin connector of the CD200D unit; the 3-pin connector end plugs into the Hall-effect pickup.

NOTE: Keep the pickup sensor wires at least 2" (50 mm) away from the coil primary wires and at least 8" (200 mm) away from the spark plug leads.

NOTE: On certain 12- and 16-cylinder engines, a cylinder other than no. 1 (typically the second cylinder in the firing order) must be used when lining up the disc and pickup.

4.0 IGNITION COILS

- 4.1 USE ONLY THE ALTRONIC COILS INDICATED HERE:
- UNSHIELDED: 501061, 591010, 591040
 - FLANGE: 591012, 591018
 - SHIELDED: 501061-S, 591010-S
 - INTEGRAL: 591007, 591011A, 591011B
- 4.2 Mount the ignition coils as close to the spark plugs as possible keeping the high-tension lead length to a minimum but also keeping temperatures below 200°F. (95°C.) during operation.

5.0 PRIMARY WIRING

- 5.1 The CD200D system requires a battery or other DC power source providing 12-30Vdc for running and a minimum of 8 volts for engine starting. Refer to FIG. 2 for details of the connection to the DC power source.
- 5.2 Primary wiring hookup is shown in the wiring diagram template – FIGS. 5 or 6.

Use the table below to record the actual firing order and wiring.

791090-8	A	B	C	D	E	F	K	L
Engine Cyl. No.								

791090-12	A	B	C	D	E	F	K	L	M	N	P	R
Engine Cyl. No.												

791090-16	A	B	C	D	E	F	K	L	M	N	P	R	S	T	U	V
Engine Cyl. No.																

The common coil ground lead on all units is the J harness lead.

- 5.3 All connections at unshielded coils should be made using ring-type terminals specified for 16 AWG (1.5 sq. mm) wire and #10 (5mm) stud size. Terminals should either be soldered to the wire or attached with an appropriate staking tool. Protect primary wiring from physical damage, vibration and temperatures in excess of 200°F. (95°C.).
- 5.4 For details of the hookup for the analog timing signal, see FIG. 7.

6.0 SHUTDOWN WIRING

- 6.1 The CD200D system is shut-off by interrupting the DC power to the unit; use a switch or relay with contacts rated 24Vdc, 10 amps - refer to FIG. 2.
- 6.2 The CD200D can also be shutdown by using the G-lead of the output harness. To shutdown the unit, connect the G-lead of the output harness to ground. The CD200D will draw about 0.1 ampere from the power source when shutdown, see FIG. 5 or 6.

7.0 SECONDARY WIRING

- 7.1 With unshielded coils, spark plug leads should be fabricated from 7mm, silicone insulated, ignition cable with suitable terminals and silicone spark plug boot.
- 7.2 Keep spark plug leads as short as possible and at least 2" (50mm) away from any grounded engine part. In deep spark plug wells, use rigid, insulated extenders projecting out of the well.
- 7.3 The use of a clear, silicone grease (such as Dow Corning DC-4, G.E. G-623 or GC Electronics Z5) is recommended for all high-tension connections and boots. This material helps seal out moisture and prevent corrosion from atmospheric sources.

WARNING: THE HOOKUP SHOWN IS FOR THE MOST COMMON ENGINE FIRING ORDER. CONNECT TO THE IGNITION COILS ACCORDING TO THE ACTUAL ENGINE FIRING ORDER.

See section 9.21 for details on programming the slave firing angle and for special wiring instructions.

NOTE: Keep the primary wiring at least 2" (50mm) away from the spark plug leads.

NOTE: Do NOT run the input power line through a series of normally closed switches.

NOTE: The CD200D should not be used to power ignition-powered panel instruments.

NOTE: The use of resistance spark plug cable or individual 5,000 ohm resistors (mounted either at the spark plug or coil) is recommended.

8.0 OPERATION

- 8.1 **IGNITION DELAY:**
On cranking, there will be a delay of two disc revolutions—after the power is ON and the engine begins rotating—before the CD200D unit commences outputs to the ignition coils. This delay is to allow identification of the pickup index hole to insure proper synchronization with the engine. A greater delay of more revolutions to allow for engine purging can be added to the programming. See section 9.10.
- 8.2 **MANUAL TIMING SWITCH:**
The CD200D unit has a TIMING switch located under a white plastic cap at the end of the case. Using a timing light, set the timing to the desired position with the engine running at NORMAL OPERATING SPEED. Replace the white cap over the timing switch once the proper timing is set. Switch position 7 gives the most advanced timing. The timing retards approximately one (1) engine degree for each switch position as the switch is moved to position 6, 5, 4, 3, 2, 1, 0. Switch position 0 is full retard. Larger timing changes per switch position can be programmed. See section 9.15.
- 8.3 **ANALOG TIMING ADJUSTMENT: (REFER TO FIG. 7)**
The CD200D unit provides for analog timing adjustment in two ways:
- 0-1,000 ohm potentiometer connected between terminals E and F of the input harness.
 - 4-20 mA signal applied to leads F and G of the input harness.
- 8.4 **RPM BASED TIMING CURVE:**
The CD200D unit is shipped with an RPM-based timing curve (default programming) providing a 6-degree advance as the engine speed increases from 0 to 600 RPM (FIG. 7). This timing change is in addition to changes made with the manual switch (section 8.2) or the analog timing input (section 8.3).

NOTE: On the first start-up after system installation, verify correct ignition timing by cranking the engine with the fuel supply shut off.

NOTE: DO NOT switch from position 7 to 0, or 0 to 7 while the engine is running. The large timing change may cause the engine to shutdown or be damaged.

NOTE: The analog timing retard is added to the retard established by the manual timing switch (see section 8.2 and FIG. 9).

NOTE: When checked at different speeds, timing will vary in accordance with the programmed RPM curve indicated.

9.0 CUSTOMIZING THE CD200D UNIT

- 9.1 **TERMINAL PROGRAM SETUP:**
The CD200D is designed to be programmed by a Personal Computer via the RS-485 Modbus communications link. See FIG. 8 for the proper hookup. The CD200D unit case must be securely grounded prior to programming.
- The Terminal Program is included on the CD-ROM supplied with each CD200D unit. The first time that the terminal software is used on a PC, the Communications Port settings must be configured in order to establish communications. After loading the Terminal Program from the CD-ROM, click on the Connection icon on the upper tool bar. The Connection Setup window will appear. The port being selected for use with the CD200D should also be set for 9600 baud, no parity, 200 ms time out (8 data bits and 1 stop bit). The PC will now be set to communicate with the CD200D. Set the ID# for the CD200D to 01.
- 9.2 **PROGRAMMING CUSTOM VALUES:**
A variety of numeric parameters can be entered by the user for customized applications or the unit can be left at the factory default settings. Changes to numeric values are made by placing the cursor in the appropriate box and typing in the new value. When the new numeric value is first typed, it appears in red text on the PC screen. The values appearing in red have not yet been sent to the CD200D unit, but are being stored on the PC until being sent. Hitting the Enter key sends the selection to the CD200D. The entered value turns green on the PC display, indicating that the new value has been successfully communicated to the CD200D and stored.
- 9.3 **SELECTING OPTIONAL FEATURES:**
Other OFF/ON programming selections are made by activating or deactivating a blue status flag on the PC screen. When the mouse pointer is located over the status flag, a double-left click activates the status flag and makes it appear to be "ON" or glowing on the PC screen, a double-right click deactivates the feature and the status flag.

NOTE: In order to program the values, the CD200D must be powered. Care should be taken in changing entries when the engine is operational to avoid unstable or dangerous operating conditions.

- 9.4 Pickup TYPE SELECTION:
OFF/ON programming selection to enable the use of a Hall-effect pickup. Requires proper harness.
- 9.5 DISC TYPE SETTING:
This numeric entry configures the Disc Type (number of holes or protrusions) on the timing disc, excluding the index. This number is normally equal to the number of cylinders on the engine for a camshaft mounted disc and $\frac{1}{2}$ the number of cylinders of the engine for a crankshaft mounted disc. This value is used to test for the correct disc and scales the rpm measurement and ignition timing angles to the specific disc chosen. Default setting = (0+1).
- Entering a value of Zero (0+1), places the ignition in auto detect mode. In auto detect mode, the ignition will automatically scale rpm measurement and ignition timing angles to the disc pattern observed.
- 9.6 Test Disc Flag:
When this status flag is ON, the CD200D will test for a match of the incoming signal pattern observed by the CD200D to the Disc Type specified. When enabled, this test is performed after synchronization to the disc pattern and before initiating firings. When the pattern does not match the setting, the ignition will not fire and the diagnostic LED on the unit will signal the error by turning off until rotation stops. Once the ignition is firing, the disc pattern will be monitored continuously and, if an error is detected, the unit will stop firing and the alarm output switch will open. Firings will be inhibited and the output switch will remain off for 5 seconds after input signals cease.
- If the shutdown lead is grounded after the unit is firing, the firings will stop, the output switch will open and remain open for 5 seconds after rotation stops.
- The diagnostic LED on the unit will turn off until rotation stops. After rotation stops it will blink the appropriate signal, see section 11.2. Default setting = OFF.
- 9.7 On Crank Flag:
When this status flag is ON, the ignition scales rpm measurement and timing angles for a signal pattern coming from a crankshaft-mounted disc. When this status flag is OFF, the ignition scales rpm measurement and timing angles for a signal pattern from a camshaft mounted disc. Default setting = OFF.
- 9.8 Line Up Angle:
This numeric entry has no impact on actual engine timing and is only used as a reference to calculate the spark timing number for display in the Terminal Software. When the pickup is aligned with the first hole or protrusion on the timing disc, the Line Up Angle is the angular position of the crankshaft with respect to TDC of the first cylinder in the firing order. Entry range is 0 to 100 engine degrees BTDC. This value will need to be fine-tuned to provide an accurate display of timing. Default setting = 40.0 degrees BTDC.
- 9.9 Insertion Retard Setting:
This numeric entry configures the minimum internal electronic input signal delay. Entry range is 2.0 to 25.5 degrees of engine retard. Default setting = 2.0 degrees.
- 9.10 Purge Delay Setting:
This numeric entry configures the number of disc rotations (engine cycles) following successful synchronization to delay before ignition outputs begin. Entry range is 0 to 255 cycles. Default setting = 0.
- 9.11 Overspeed Setting:
This numeric entry configures the engine rpm at which the ignition will stop firing outputs due to an overspeed condition. The overspeed condition also turns off the alarm output switch. When rotation has fully stopped, the LED on the CD200D unit will blink the appropriate code and the alarm output switch is restored to normal (closed). Default setting = 2200 RPM.

NOTE: Pickup type selection is critical and must be properly configured to match the pickup type in use.

NOTE: The disc test for a specific number of pulses is not performed in auto detection mode (0 entry for Disc Type Setting – section 9.5).

- 9.12 **Run Speed Setting:**
This numeric entry configures the transition speed from crank to run. This setting also determines the transition of the diagnostic LED on the CD200D from crank to run modes. Default setting = 500 RPM.
- 9.13 **Low Voltage Setting:**
This numeric entry configures the threshold for the low voltage diagnostic of the DC input voltage to the CD200D. If the DC voltage decreases to this setting, the diagnostic LED on the CD200D will blink the appropriate code. The CD200D will continue to try to fire outputs regardless of the voltage. Default setting = 6 volts.
- 9.14 **Enable LED Diagnostics Flag:**
When this LED status flag is activated, the blink code diagnostics for primary and secondary outputs are enabled. Default setting is ON.
- 9.15 **Switch CAL:**
These numeric entries configure the timing retard for each position of the manual timing switch on the CD200D case. Entry range is 0 to 25.5 degrees of engine retard. The active entry is indicated in blue. Default setting is 7-6-5-4-3-2-1. If two degrees change per switch position is desired, enter 14-12-10-8-6-4-2.
- 9.16 **Loop CAL:**
These numeric entries configure the interpolated lookup table for the ignition retard versus the analog current loop input signal. This allows the operator to create custom spark timing maps versus the current loop input signal. Entry range is 0 to 25.5 degrees of engine retard. The active entries are indicated in blue. Default sequence is 0 degrees retard at 4mA, 16 degrees retard at 20mA.
- 9.17 **RPM CAL:**
These numeric entries configure the interpolated lookup table for retard versus the engine speed. This allows the operator to create custom spark timing maps versus engine rpm. Entry range is 0 to 25.5 degrees of engine retard. The active entries are indicated in blue. Default sequence is 6 degrees retard at 0 RPM, decreasing to 0 degrees retard at 600 RPM.
- 9.18 **Cylinder CAL:**
These numeric entries configure the amount of individual offset timing retard added to the global timing for each individual output. This feature can be used to map an evenly spaced timing disc to an odd firing angle engine pattern. Entry range is 0 to 50 degrees of engine retard. Default settings are 0. Contact the factory for further details of this feature.
- 9.19 **Energy Flags:**
Select one of four output energy settings for the CD200D:
- | | | | | |
|-------|-----|-------|-----|------------------|
| Bit 1 | OFF | Bit 0 | OFF | Vcap = 150 volts |
| Bit 1 | OFF | Bit 0 | ON | Vcap = 160 volts |
| Bit 1 | ON | Bit 0 | OFF | Vcap = 170 volts |
| Bit 1 | ON | Bit 0 | ON | Vcap = 180 volts |
- Default setting is 160 volts at the capacitor. This voltage can only be measured using a device with an input impedance of 1 megaohm or higher with no other device connected.
- 9.20 **Enable Slave Firing Flag:**
When this LED status flag is activated, the ignition will generate a second slave firing for each (x+1) reference pulse. For a (6+1) disc pattern, the ignition will fire 12 outputs when this flag is activated, and 6 outputs when this flag is not activated. Modification of this flag through the Terminal Program requires that the engine be stopped and the G-lead be grounded.

9.21 SLAVE FIRING ANGLE SETTING:

This numeric entry configures the angle of the slave firing relative to the standard firings that are generated for each (x+1) reference pulse. Entry range is 25.0° to 60.0° which is used to set the slave firing angle on a 12 or 16-cylinder, 4-cycle engine. The slave angle must be the smaller of the two angles that define the engine firing pattern. For example, firing patterns of either 30°–90° or 90°–30° would require the slave angle be entered as “30”. Modification of this value through the Terminal Program requires that the engine be stopped and the G1 lead be grounded.

NOTE: All 16-cylinder applications must be slave-firing patterns utilizing an 8+1 disc.

Common slave-firing patterns:

NO. CYLS.	Engine Firing Angle	SECT. 9.4 DISC SETTING	SECT. 9.20 SLAVE ANGLE	IN FIRING ORDER, OUTPUT A CONNECTS TO:
8	60°–120°	4+1	60°	First cylinder
8	120°–60°	4+1	60°	Second cylinder
10	54°–90°	5+1	54°	First cylinder
10	90°–54°	5+1	54°	Second cylinder
12	30°–90°	6+1	30°	First cylinder
12	40°–80°	6+1	40°	First cylinder
12	50°–70°	6+1	50°	First cylinder
12	55°–65°	6+1	55°	First cylinder
12	60°–even	6+1	60°	First cylinder
12	75°–45°	6+1	45°	Second cylinder
12	90°–30°	6+1	30°	Second cylinder
16	30°–90°	8+1	30°	First cylinder
16	45°–even	8+1	45°	First cylinder
16	90°–30°	8+1	30°	Second cylinder

10.0 PC TERMINAL DISPLAY FUNCTIONS

- 10.1 Engine Speed:
Indicates current speed of the engine in RPM based on disc signal.
- 10.2 Spark Timing:
Indicates the global spark timing of the engine in degrees before TDC. This number is the LINE UP ANGLE setting less the TOTAL RETARD. Slight differences between this number and the timing reading obtained with a timing light may occur since the LINE UP ANGLE entered may differ slightly from the actual angular position of the engine when the input pulse event is received by the CD200D. In this event, the Spark Timing number should be made to agree with the timing light by changing the LINE UP ANGLE entry.
- 10.3 Switch Position:
Indicates the current position of the manual timing switch on the CD200D case.
- 10.4 Loop Input:
Indicates the value of the external input current loop.
- 10.5 Observed Disc:
Indicates the number of input events (timing holes, protrusions or magnets) being recognized by the CD200D unit on the timing disc input signal at this time.
- 10.6 Insertion Retard:
Indicates the amount of electronic insertion retard at this time.

- 10.7 Switch Retard:
Indicates the amount of timing retard being added by the current timing switch position at this time.
- 10.8 Loop Retard:
Indicates the actual amount of timing retard added from the current loop versus retard lookup table curve at this time.
- 10.9 RPM Retard:
Indicates the actual amount of timing retard being added by the RPM versus retard lookup table curve at this time.
- 10.10 TOTAL Retard:
Indicates the total global timing retard at this time. This number is the sum of the Insertion Retard, Switch Retard, Loop Retard and RPM Retard.
- 10.11 Counter:
Indicates the number of disc rotations (engine cycles) registered since the engine was last started.
- 10.12 Purge Counter:
During a startup, indicates the number of purge cycles remaining before the outputs are activated.
- 10.13 Supply Voltage:
Indicates the measured DC voltage supply level to the CD200D.
- 10.14 Spark Ref. (A, B, C, etc.):
Indicates the current spark reference number for each cylinder.
- 10.15 Syncing:
When red, indicates that engine rotation has been sensed and the synchronization process is taking place.
- 10.16 Insync1:
When red, indicates that the index input has been recognized once.
- 10.17 Insync2:
When red, indicates that the index has been recognized a second time and the ignition is ready to proceed.
- 10.18 Purging:
When red, indicates that synchronization has been completed and the purge cycle countdown is taking place.
- 10.19 Trying:
When red, indicates that the CD200D is trying to fire outputs, but a proper primary discharge event has not yet occurred.
- 10.20 Firing:
When red, indicates that CD200D is successfully firing primary outputs.
- 10.21 LOCKOUT:
When red, indicates that firings are locked out until engine rotation has ceased for a minimum of 5 seconds.
- 10.22 Cranking:
When red, indicates engine rotation below the Run Speed setting.
- 10.23 Running:
When red, indicates engine rotation above the Run Speed setting.
- 10.24 Disc Error:
When red, indicates that the Test Disc status flag is activated and the timing disc pattern being sensed did not match the DISC TYPE selected.

- 10.25 G-Lead:
When red, indicates that the G-lead is grounded.
- 10.26 Remote:
When red, indicates a remote serial shutdown command is active.
- 10.27 SD-Lead:
When red, indicates that a shutdown has occurred which was the result of a grounded G-lead condition.
- 10.28 SD-Remote:
When red, indicates that a shutdown has occurred as a result of a remote serial shutdown command.
- 10.29 SD-Overspeed:
When red, indicates that a shutdown has occurred as a result of the engine reaching the Overspeed setting.
- 10.30 Wdog1:
When red, indicates that the microprocessor has re-booted since the ignition has been powered-up.
- 10.31 Wdog2:
When red, indicates that the microprocessor is currently re-booting. Disregard the first blink when first connecting.
- 10.32 ChkSum:
When red, indicates a microprocessor checksum error.
- 10.33 Low Volt:
When red, indicates that the input DC voltage is at or below the Low Voltage setting input.
- 10.34 No Charge:
When red, indicates that the primary storage capacitor has failed to charge properly within the last ~2 seconds.
- 10.35 Primary Open:
When red, indicates that an open primary condition has been detected within the last ~2 seconds.
- 10.36 Primary Short:
When red, indicates that a shorted primary condition has been detected within the last ~2 seconds.
- 10.37 Secondary Open:
When red, indicates that an open secondary condition has been detected within the last ~2 seconds.
- 10.38 Cranks Log:
Indicates the total number of crank attempts seen by the CD200D.
- 10.39 Starts Log:
Indicates the total number of successful starts seen by the CD200D as defined by the Run Speed setting input.
- 10.40 Cycle Log:
Total number of engine cycles seen by the CD200D.
- 10.41 Cold Boot Log:
Indicates the number of times the input DC voltage has been cycled to zero.
- 10.42 Warm Boot Log:
Indicates the number of times the microprocessor has restarted without a complete loss of power.

- 10.43 Graphic Display:
The CD200D Terminal Software provides a real time graphic display of the secondary diagnostic numbers, global engine timing (y-axis/10) and engine speed (y-axis x 10).

11.0 CD200D UNIT LED DIAGNOSTIC BLINK CODES

- 11.1 CD200D IGNITION BLINK CODES:
Whenever the LED Diags status flag is enabled (blue) by using the CD200D Terminal Software, the blinking pattern of the LED on the side of the CD200D case can be used to interpret the general status of the CD200D diagnostics without the use of the Terminal Software. Within each group of conditions described below, the possible diagnostic states are listed according to their number of blinks. The LED is ON for about 2 seconds between each blink sequence and the blinks occur evenly spaced at a faster rate.
- 11.2 LED SIGNALS WITH THE ENGINE STOPPED:
- ON – Steady = READY (new power up or last start attempt aborted)
 - ON – 1 Blink – ON = FIRED LAST TIME ROTATING (stopped due to stall)
 - ON – 2 Blink – ON = SHUTDOWN (By grounding G-LEAD when running)
 - ON – 3 Blink – ON = SHUTDOWN (By Remote Serial Request when running)
 - ON – 4 Blink – ON = SHUTDOWN (By Overspeed when running)
 - ON – 5 Blink – ON = WRONG DISK PATTERN
 - ON – 6 Blink – ON = LOW SUPPLY VOLTAGE (Below Threshold when running)
- 11.3 LED SIGNALS WITH ENGINE CRANKING:
Rotating, and still below running RPM.
- ON/OFF/ON/OFF = PURGING (off first input pulse, toggles each revolution of purge)
 - ON – Steady = FIRING NORMALLY (RPM below running set point value)
 - OFF = WRONG DISC PATTERN DETECTED
- 11.4 LED SIGNALS WITH ENGINE RUNNING:
When firing, and above run speed.
- ON – Steady = FIRING NORMALLY (No Diagnostics to Report)
 - ON – 1 Blink – ON = OPEN SECONDARY ALARM
 - ON – 2 Blink – ON = PRIMARY SHORT ALARM
 - ON – 3 Blink – ON = PRIMARY OPEN ALARM
 - ON – 4 Blink – ON = NO CHARGE ALARM
 - ON – 6 Blink – ON = LOW SUPPLY VOLTAGE

12.0 RS-485 COMMUNICATIONS, MODBUS RTU

- 12.1 The CD200D is compliant to the Modicon Modbus RTU standard. Maximum number of registers that can be read at one time is limited to 32. Maximum number of booleans that can be read at one time is limited to 256. All communications are 8 data bits, no parity, 1 stop bit. The baud rate is 9600. The MODBUS address list follows:
- 12.2 24 READ-ONLY STATUS BITS
 READABLE IN MULTIPLES OF 8 BITS
 STARTING AT 8-BIT BOUNDARIES

ADDRESS	FUNCTION
10001	Syncing
10002	InSync1
10003	InSync2
10004	Purging
10005	Trying
10006	Firing
10007	LockOut
10008	FIRED
10009	Cranking
10010	Running
10011	Wrong Disk
10012	GLead Shutdown Grounded
10013	Remote Shutdown Present
10014	GLead Shutdown Logged
10015	Remote Shutdown Logged
10016	Overspeed Shutdown Logged
10017	WDOG1 Reset Latched
10018	WDOG2 Reset Event
10019	CheckSum Error
10020	LOW Supply Voltage
10021	No Charge
10022	Open Primary
10023	Shorted Primary
10024	Open Secondary

12.3 READ ONLY STATUS REGISTERS

ADDRESS	FUNCTION
30001	Input Bit Mirror 10016-10001
30002	Input Bit Mirror 10032-10017
30003	Input Bit Mirror 10048-10033
30004	Input Bit Mirror 10064-10049
30005	RPM
30006	Timing xxx.xDEG signed
30007	Switch Position 1-8
30008	Current Loop Input xx.xmA
30009	Disk Observed X+1
30010	Insertion Retard xxx.xDeg
30011	Switch Retard xxx.xDeg
30012	Loop Retard xxx.xDeg
30013	RPM Retard xxx.xDeg
30014	Total Retard xxx.xDeg
30015	Cycle Counter HI
30016	Cycle Counter LO
30017	Supply Voltage xx.xVolts
30018	Spark Ref. Num. Output A
30019	Spark Ref. Num. Output B
30020	Spark Ref. Num. Output C
30021	Spark Ref. Num. Output D
30022	Spark Ref. Num. Output E
30023	Spark Ref. Num. Output F
30024	Spark Ref. Num. Output K
30025	Spark Ref. Num. Output L
30026	Spark Ref. Num. Output M
30027	Spark Ref. Num. Output N
30028	Spark Ref. Num. Output P
30029	Spark Ref. Num. Output R
30030	Spark Ref. Num. Output S
30031	Spark Ref. Num. Output T
30032	Spark Ref. Num. Output U
30033	Spark Ref. Num. Output V
30034	Purge Delay Index Down Counter
30035	Distributor MUX code 0-15
30036	KEYCOMMAND
30037	Period Predivider
30038	Period MS16BITS
30039	Period LS16BITS
30040	FireStat:DelayStat

12.4 8 READ/WRITE CONFIGURATION BITS
SUPPORTS WRITE SINGLE ONLY
READABLE IN MULTIPLES OF 8 BITS
STARTING AT 8 BIT BOUNDARIES

ADDRESS	FUNCTION
00001	DISK ON CAM=0 CRANK=1
00002	TEST FOR PROPER DISK YES=1
00003	ENABLE SECONDARY DIAGS YES=1
00004	ENERGY BIT0 00=~160 01=~170
00005	ENERGY BIT1 10=~180 11=~190
00006	SLAVE
00007	reserved
00008	OFF = MAGNETIC Pickup ON = HALL-EFFECT Pickup

12.5 4 READ/WRITE REGISTERS MIRROR COIL BITS

ADDRESS	FUNCTION
40001	REG40001=CoilBits 00016-00001
40002	REG40002=CoilBits 00032-00017
40003	REG40003=CoilBits 00048-00033
40004	REG40004=CoilBits 00064-00049

12.6 8 READ/WRITE REGISTERS REGARDING APPLICATION

ADDRESS	FUNCTION
40005	Disk+1 2,3,4,5,6,7,8,9,10,12
40006	Disk Lineup to TDC xx.x DEG
40007	Insertion Ret MIN=2.0 DEG xx.x
40008	Purge Delay Cycles 0-255
40009	RPM Over Speed Setpoint
40010	RPM Crank to Run Threshold
40011	Low Supply Voltage Limit xx.xV
40012	SLAVE ANGLE xx.x DEG

12.7 12 READ/WRITE REGISTERS FOR CYLINDER RET. TABLE

ADDRESS	FUNCTION
40017	OUTPUT A EXTRA RETARD DEG
40018	OUTPUT B EXTRA RETARD DEG
40019	OUTPUT C EXTRA RETARD DEG
40020	OUTPUT D EXTRA RETARD DEG
40021	OUTPUT E EXTRA RETARD DEG
40022	OUTPUT F EXTRA RETARD DEG
40023	OUTPUT K EXTRA RETARD DEG
40024	OUTPUT L EXTRA RETARD DEG
40025	OUTPUT M EXTRA RETARD DEG

ADDRESS	FUNCTION
40026	OUTPUT N EXTRA RETARD DEG
40027	OUTPUT P EXTRA RETARD DEG
40028	OUTPUT R EXTRA RETARD DEG
40029	OUTPUT S EXTRA RETARD DEG
40030	OUTPUT T EXTRA RETARD DEG
40031	OUTPUT U EXTRA RETARD DEG
40032	OUTPUT V EXTRA RETARD DEG

12.8 8 READ/WRITE REGISTERS FOR TIMING SWITCH RET. TABLE

ADDRESS	FUNCTION
40033	TIMING SWITCH POS 0 DEG
40034	TIMING SWITCH POS 1 DEG
40035	TIMING SWITCH POS 2 DEG
40036	TIMING SWITCH POS 3 DEG
40037	TIMING SWITCH POS 4 DEG
40038	TIMING SWITCH POS 5 DEG
40039	TIMING SWITCH POS 6 DEG
40040	TIMING SWITCH POS 7 DEG

12.9 21 READ/WRITE REGISTERS FOR LOOP RET. TABLE

ADDRESS	FUNCTION
40049	LOOP RET MAP 0mA 0.00V DEG
40050	LOOP RET MAP 1mA 0.25V DEG
40051	LOOP RET MAP 2mA 0.50V DEG
40052	LOOP RET MAP 3mA 0.75V DEG
40053	LOOP RET MAP 4mA 1.00V DEG
40054	LOOP RET MAP 5mA 1.25V DEG
40055	LOOP RET MAP 6mA 1.50V DEG
40056	LOOP RET MAP 7mA 1.75V DEG
40057	LOOP RET MAP 8mA 2.00V DEG
40058	LOOP RET MAP 9mA 2.25V DEG
40059	LOOP RET MAP 10mA 2.50V DEG
40060	LOOP RET MAP 11mA 2.75V DEG
40061	LOOP RET MAP 12mA 3.00V DEG
40062	LOOP RET MAP 13mA 3.25V DEG
40063	LOOP RET MAP 14mA 3.50V DEG
40064	LOOP RET MAP 15mA 3.75V DEG
40065	LOOP RET MAP 16mA 4.00V DEG
40066	LOOP RET MAP 17mA 4.25V DEG
40067	LOOP RET MAP 18mA 4.50V DEG
40068	LOOP RET MAP 19mA 4.75V DEG
40069	LOOP RET MAP 20mA 5.00V DEG

12.10 31 READ/WRITE REGISTERS FOR RPM RET. TABLE

ADDRESS	FUNCTION
40070	RPM RET MAP 0000 RPM DEG
40071	RPM RET MAP 0100 RPM DEG
40072	RPM RET MAP 0200 RPM DEG
40073	RPM RET MAP 0300 RPM DEG
40074	RPM RET MAP 0400 RPM DEG
40075	RPM RET MAP 0500 RPM DEG
40076	RPM RET MAP 0600 RPM DEG
40077	RPM RET MAP 0700 RPM DEG
40078	RPM RET MAP 0800 RPM DEG
40079	RPM RET MAP 0900 RPM DEG
40080	RPM RET MAP 1000 RPM DEG
40081	RPM RET MAP 1100 RPM DEG
40082	RPM RET MAP 1200 RPM DEG
40083	RPM RET MAP 1300 RPM DEG
40084	RPM RET MAP 1400 RPM DEG
40085	RPM RET MAP 1500 RPM DEG
40086	RPM RET MAP 1600 RPM DEG
40087	RPM RET MAP 1700 RPM DEG
40088	RPM RET MAP 1800 RPM DEG
40089	RPM RET MAP 1900 RPM DEG
40090	RPM RET MAP 2000 RPM DEG
40091	RPM RET MAP 2100 RPM DEG
40092	RPM RET MAP 2200 RPM DEG
40093	RPM RET MAP 2300 RPM DEG
40094	RPM RET MAP 2400 RPM DEG
40095	RPM RET MAP 2500 RPM DEG
40096	RPM RET MAP 2600 RPM DEG
40097	RPM RET MAP 2700 RPM DEG
40098	RPM RET MAP 2800 RPM DEG
40099	RPM RET MAP 2900 RPM DEG
40100	RPM RET MAP 3000 RPM DEG

12.11 7 READ/WRITE MISC. REGISTERS

ADDRESS	FUNCTION
40122	Crank Counter
40123	Start Counter
40124	Cycle Counter HIGH
40125	Cycle Counter LOW
40126	REG40005 MSB=BAUD LSB=NODEID fixed 9600n81:node1
40127	Cold Boot (powerup) Count
40128	Warm Boot (reset) Count

FIGURE 1 — CD200D DIMENSIONS & SPECIFICATIONS

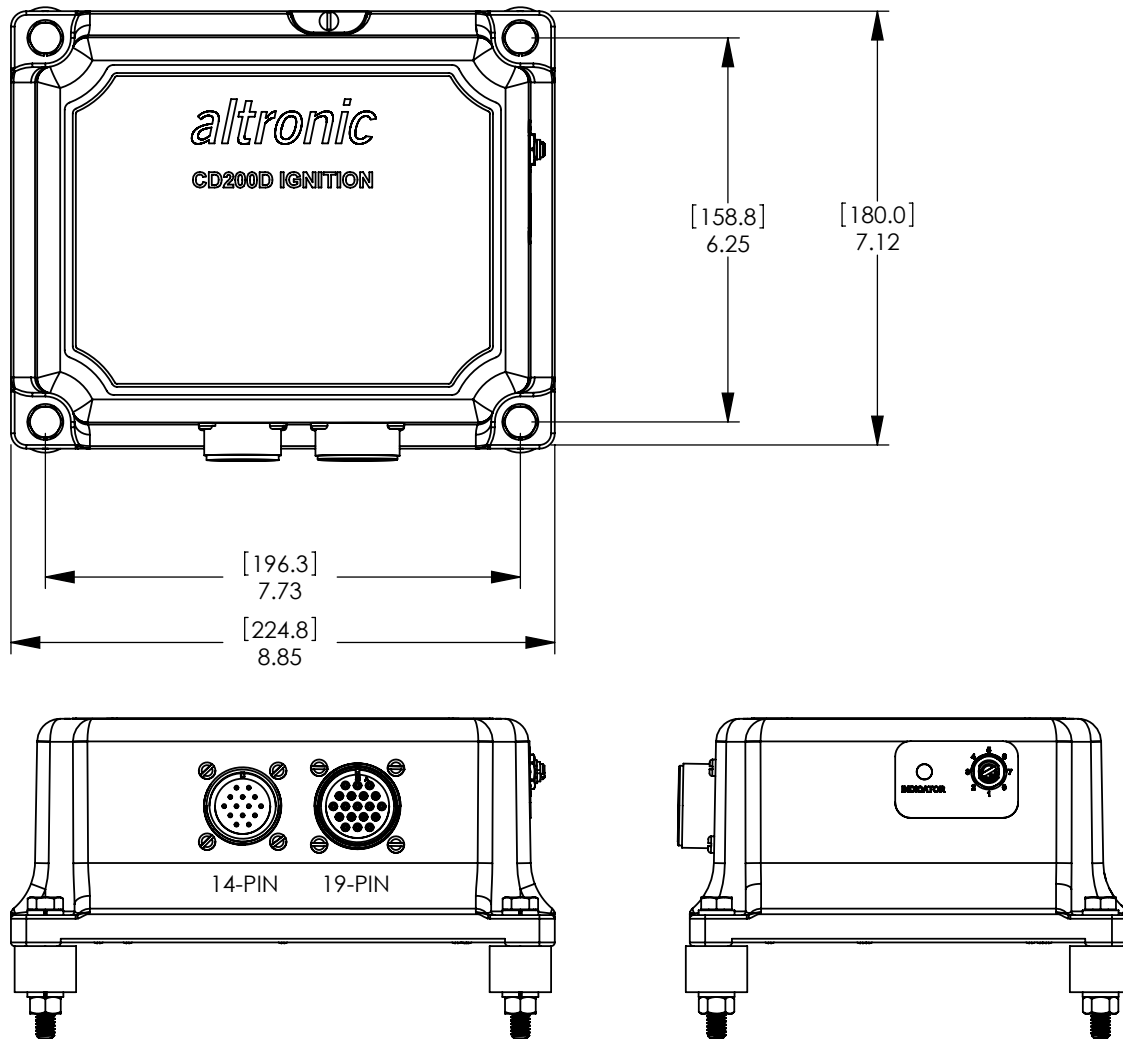

14-PIN CONNECTOR	
CONN. PIN	PCB HOLE
A	MPA
B	MPB
C	485 +
D	FLT
E	+5V
F	4-20 IN
G	4-20 -
H	485 -
I	N/C
J	N/C
K	+24
L	HEA
M	HEB
N	HEC

OPERATING TEMPERATURE: -40°C TO +85°C
 STORAGE TEMPERATURE: -40°C TO +105°C
 INPUT VOLTAGE: 12 TO 30 VDC
 OUTPUT VOLTAGE: 160 VDC NOM.

FIGURE 2 — CD200D OPERATING VOLTAGE REQUIREMENT

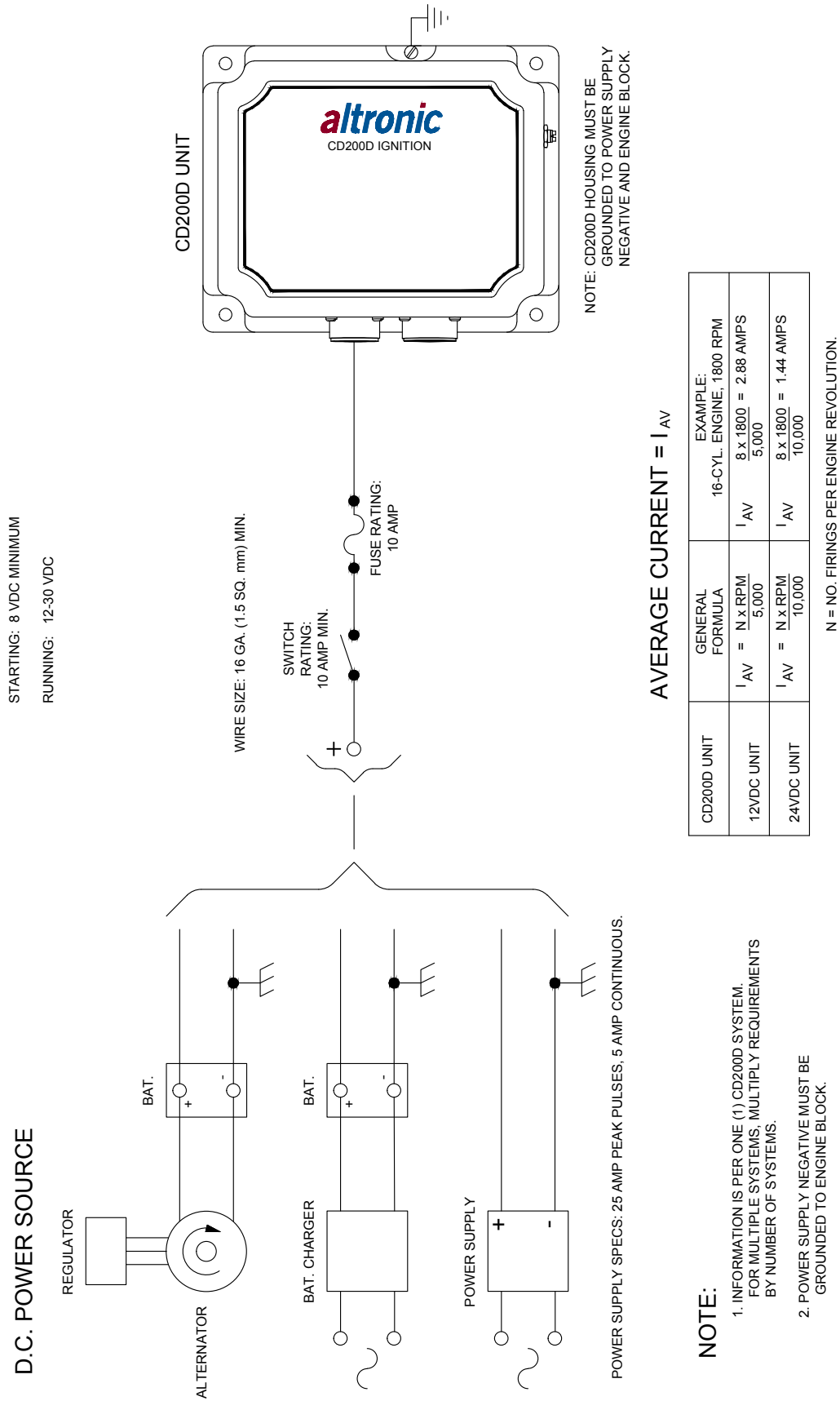

FIGURE 3 — CD200D MAGNETIC PICKUP AND DISC HOLE DETAIL

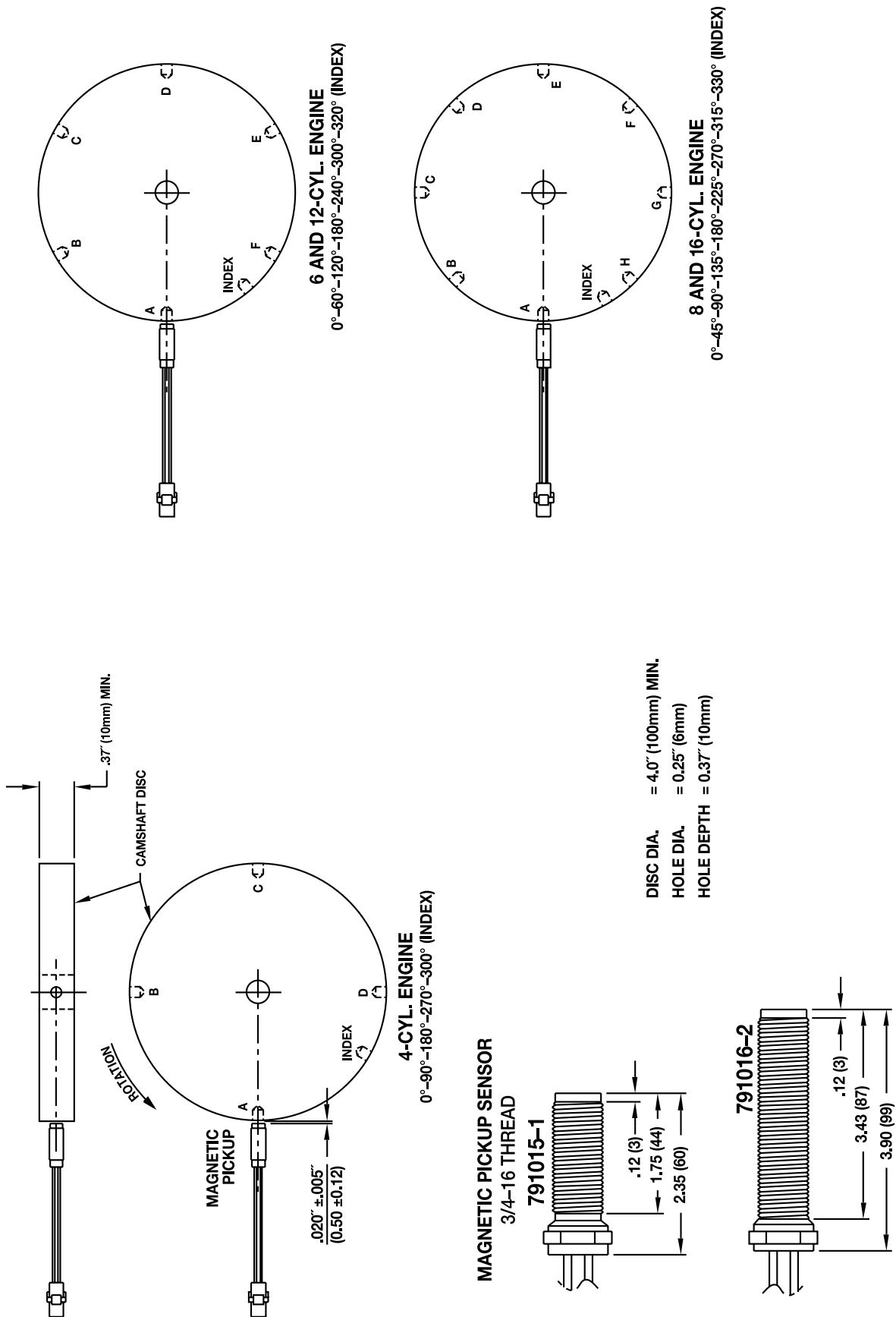
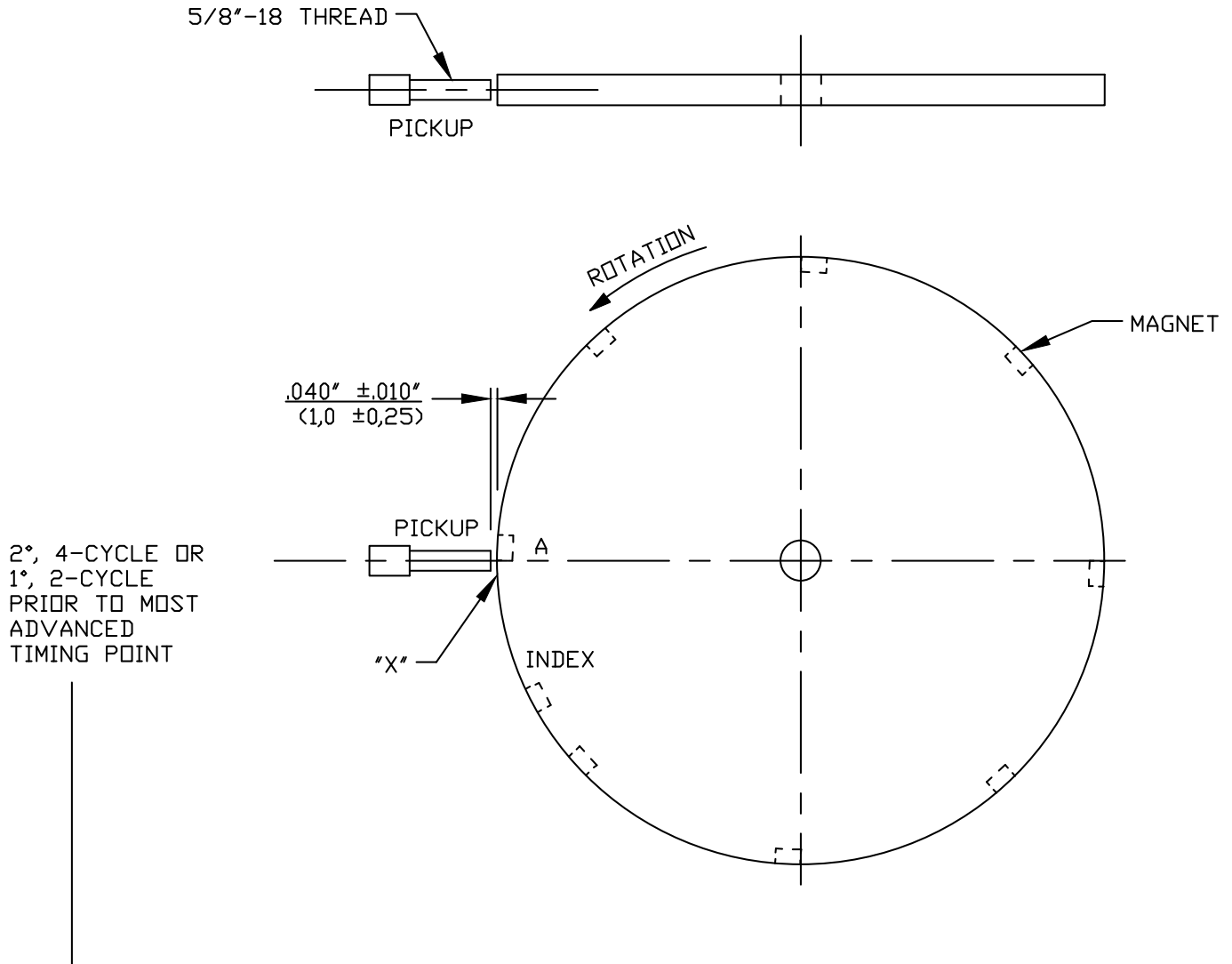

FIGURE 4 — CD200D PICKUP AND DISC INSTALLATION



EXAMPLE: (4-CYCLE ENGINE)

MOST ADVANCED TIMING SETTING = 24° BTDC
 ENGINE SETTING FOR ABOVE LINE-UP = 26° BTDC
 ADJUSTABLE TIMING RANGE = 9°-24° BTDC

NOTE: (8 + 1) MAGNET DISC SHOWN.

FIGURE 5 — CD200D WIRING DIAGRAM TEMPLATE FOR SINGLE-FIRING SYSTEM WITH MAGNETIC PICKUP

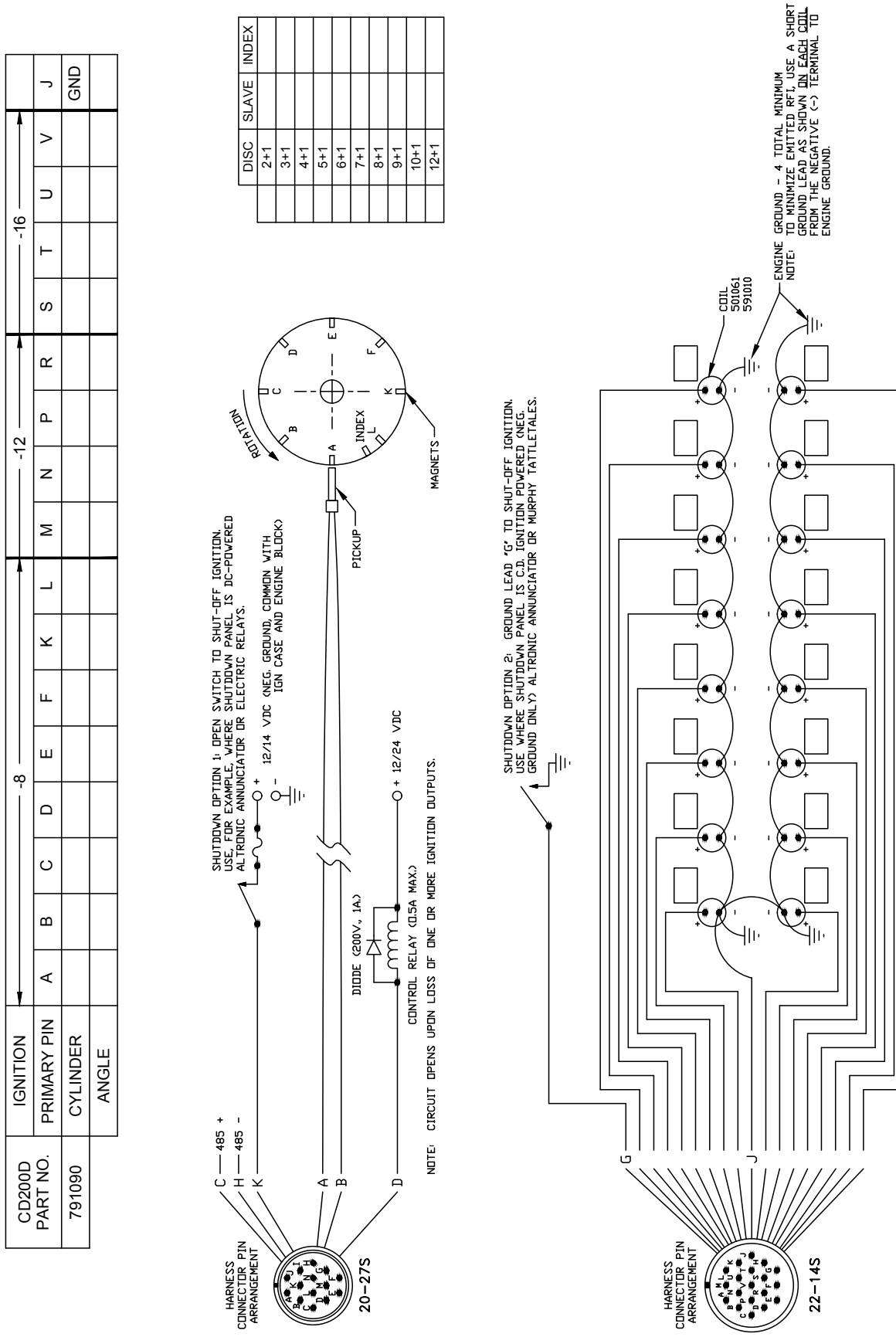
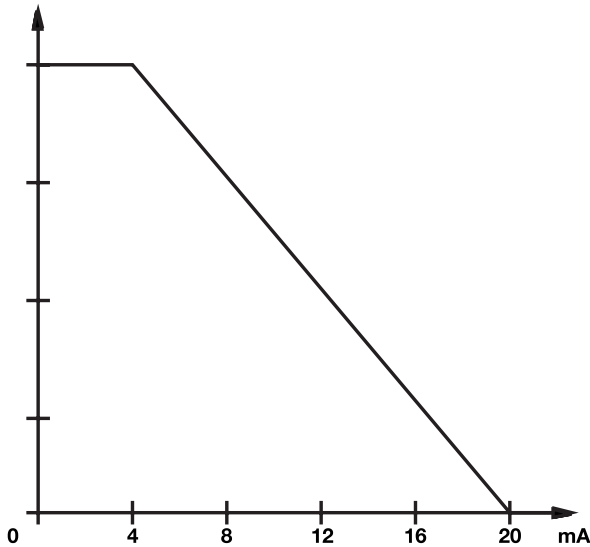
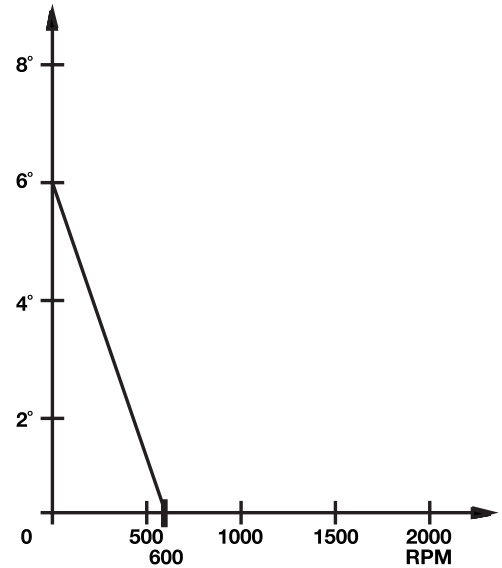

FIGURE 7 — CD200D HOOK-UP FOR ANALOG TIMING SIGNAL

EXAMPLE ANALOG TIMING CURVE – ENGINE DEGREES DEGS. RETARD



EXAMPLE SPEED TIMING CURVE – ENGINE DEGREES DEGS. RETARD



14-PIN INPUT/CONTROL CONNECTOR WIRING
OPTION 1 — POTENTIOMETER CONTROL

PIN A	PIN B	PIN C	PIN D	PIN E	PIN F	PIN G	PIN H	PIN J	PIN K	PIN L	PIN M	PIN N
+ MPU INPUT	- MPU INPUT	485 +	FAULT OUT	+5VDC 100mA MAX	ANALOG +	ANALOG -	485 -	N/C	+12/24VDC	HEA	HEB	HEC



OPTION 2 — 4-20mA CONTROL

PIN A	PIN B	PIN C	PIN D	PIN E	PIN F	PIN G	PIN H	PIN J	PIN K	PIN L	PIN M	PIN N
+ MPU INPUT	- MPU INPUT	485 +	FAULT OUT	+5VDC 100mA MAX	ANALOG +	ANALOG -	485 -	N/C	+12/24VDC	HEA	HEB	HEC

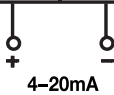

NOTE: INPUT CONNECTOR CIRCUIT AT PIN "D" OPENS WHEN ENGINE RPM EXCEEDS OVERSPEED SETTING. THE CIRCUIT REMAINS OPEN UNTIL ROTATION STOPS FOR APPROXIMATELY 4 SECONDS.

FIGURE 8 — PC TO CD200D

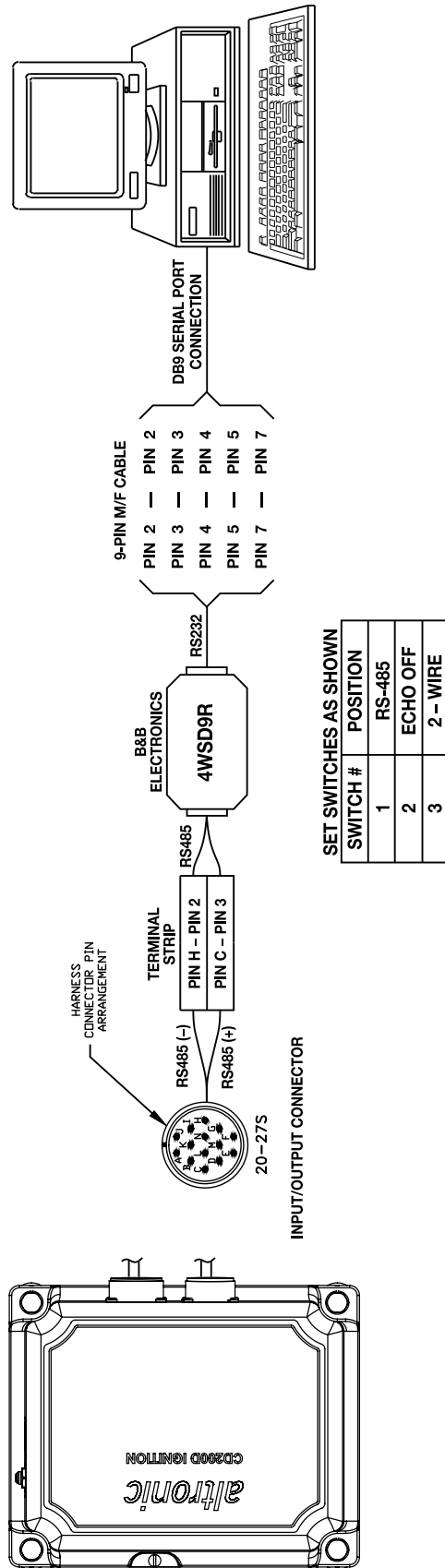

FIGURE 9 — CD200D TERMINAL PROGRAM SCREEN

Altronic CD200/CD200D Terminal Program

Connection ResetComStats Disconnect DeviceConfig Snapshot LogFile HotKeys Help Exit

ID# 1 0.255 V4.2.06/01/2010 CD2000 791090-16

Engine Speed 1796 rpm Cranking Syncing Insync1 Insync2 Purging Tying Firing LockOut Fired Wdog1 No Charge Wdog2 Primary Open Chk-Sum Primary Short Low Volt Secondary Open

Spark Timing 25.2 °bdc Running Disc Error GLead Remote SD-GLead SD-Remote SD-Overspeed

Switch Pos. 2 position Disc Error GLead Remote SD-GLead SD-Remote SD-Overspeed

Loop Input 11.9 ma 8 +1 2.0 °ret 5.0 °ret 7.8 °ret 0.0 °ret 14.8 °ret 24600 Cycles 0 Cycles 24.1 Volts

Observed Disc 8 +1 2.0 °ret 5.0 °ret 7.8 °ret 0.0 °ret 14.8 °ret 24600 Cycles 0 Cycles 24.1 Volts

Insertion Retard 2.0 °ret 5.0 °ret 7.8 °ret 0.0 °ret 14.8 °ret 24600 Cycles 0 Cycles 24.1 Volts

Switch Retard 5.0 °ret 7.8 °ret 0.0 °ret 14.8 °ret 24600 Cycles 0 Cycles 24.1 Volts

Loop Retard 7.8 °ret 0.0 °ret 14.8 °ret 24600 Cycles 0 Cycles 24.1 Volts

RPM Retard 0.0 °ret 14.8 °ret 24600 Cycles 0 Cycles 24.1 Volts

TOTAL Retard 14.8 °ret 24600 Cycles 0 Cycles 24.1 Volts

Counter 24600 Cycles 0 Cycles 24.1 Volts

Purge Counter 0 Cycles 24.1 Volts

Supply Voltage 24.1 Volts

test disc Disc Type Setting 8 +1 on crank +1

LineUp Angle Setting 40.0 °bdc

Insertion Ret Setting 2.0 °ret

Purge Delay Setting 0 cycles

Overspeed Setting 2300 rpm

Run Speed Setting 200 rpm

Low Voltage Setting 6.0 volts

Enable LED Energy Bit 1 Energy Bit 0

Diags Slave Firing 30.0 Deg

Cranks Log 15 counts

Starts Log 15 counts

Cycle Log 45147 counts

Cold Boot Log 6 counts

Warm Boot Log 0 counts

Diags 149 152 150 155 147 150 146 148 150 150 149 159 148 150 151 151

Cylinder-CAL A 0.0 °ret B 0.0 °ret C 0.0 °ret D 0.0 °ret E 0.0 °ret F 0.0 °ret K 0.0 °ret L 0.0 °ret M 0.0 °ret N 0.0 °ret P 0.0 °ret R 0.0 °ret S 0.0 °ret T 0.0 °ret U 0.0 °ret V 0.0 °ret

Switch-CAL #0 7.0 °ret #1 6.0 °ret #2 5.0 °ret #3 4.0 °ret #4 3.0 °ret #5 2.0 °ret #6 1.0 °ret #7 0.0 °ret

Loop-CAL 0ma 0.0 °ret 1ma 0.0 °ret 2ma 0.0 °ret 3ma 0.0 °ret 4ma 0.0 °ret 5ma 1.0 °ret 6ma 2.0 °ret 7ma 3.0 °ret 8ma 4.0 °ret 9ma 5.0 °ret 10ma 6.0 °ret 11ma 7.0 °ret 12ma 8.0 °ret 13ma 9.0 °ret 14ma 10.0 °ret 15ma 11.0 °ret 16ma 12.0 °ret 17ma 13.0 °ret 18ma 14.0 °ret 19ma 15.0 °ret 20ma 16.0 °ret

RPM-CAL 0 6.0 °ret 100 5.0 °ret 200 4.0 °ret 300 3.0 °ret 400 2.0 °ret 500 1.0 °ret 600 0.0 °ret 700 0.0 °ret 800 0.0 °ret 900 0.0 °ret 1000 0.0 °ret 1100 0.0 °ret 1200 0.0 °ret 1300 0.0 °ret 1400 0.0 °ret 1500 0.0 °ret 1600 0.0 °ret 1700 0.0 °ret 1800 0.0 °ret 1900 0.0 °ret 2000 0.0 °ret 2100 0.0 °ret 2200 0.0 °ret 2300 0.0 °ret 2400 0.0 °ret 2500 0.0 °ret 2600 0.0 °ret 2700 0.0 °ret 2800 0.0 °ret 2900 0.0 °ret 3000 0.0 °ret

Hall Effect Pickup

COM8: 9600,n,8,1:Communicating Polls: 1498 Errs: 1 Timeout (Read40097)