

Ignition Accessories

altronic



Ignition Accessories

CONTENTS

Introduction	3
Altronic EZRail® Modular Ignition Rail System	
Features and Benefits	4
System Components for High Speed Engines.....	5
System Components for Integral Engines	6
Altronic Spark Plug Leads	
Features and Benefits	7
Universal FLASHGUARD® Leads	8
Assembled FLASHGUARD® Leads	9
Other Spark Plug Leads.....	10
Altronic FLASHGUARD® Industrial Spark Plugs	
Features and Benefits	11
Types and Part Numbers.....	12
Application List.....	13
Accessories	14-15



CERTIFIED FOR USE IN HAZARDOUS LOCATIONS
NOTE: Most, but not all, Altronic ignition systems and accessories in this catalog are CSA certified and compliant with the appropriate CE/ATEX regulations. Check each product listing for certification and hazardous area classification.

Introduction

Altronic Industrial Ignition Accessories

With tens of thousands of systems in daily service worldwide, Altronic's ignition systems, EZRail® modular wiring rails, ignition coils, secondary leads, and spark plugs are recognized by industrial engine operators as the finest such products in the world.

This doesn't happen by accident.

It begins with a commitment to our customers that combines over fifty years of product design and engineering experience with the finest materials available. Add an ISO 9001-certified manufacturing process to this formula, and our customers get products that deliver the kind of extended, trouble-free service that the oil and gas/power generation industries expect and demand. Products that reduce operating costs by minimizing downtime while shortening and simplifying troubleshooting.

This attention to detail is evident in every ignition system component and accessory, as well. EZRail® and FLASHGUARD® secondary leads and spark plugs are designed and built to insure that every ignition system — whether an Altronic III, Altronic V, CPU-95, or CPU-2000 — delivers the necessary energy for consistently efficient combustion.

As you review the products in the pages that follow, consider the following:

- Automotive and industrial engine applications are as different as night and day. Altronic ignition accessories are specifically engineered and constructed for trouble-free service on demanding 24/7 oilfield and power generation-based engines.
- The EZRail® modular ignition rail system is a factory-built, tested, and certified assembly designed to eliminate field wiring and troubleshooting.
- Altronic FLASHGUARD® secondary leads and spark plugs incorporate integral resistors to insure uninterrupted service from engine-room based control systems and electronics.
- All Altronic FLASHGUARD® secondary leads are re-buildable by the user. This approach insures a maximum return on investment and optimum performance.
- FLASHGUARD® spark plugs feature extended insulators and a patented “nose cone” design to resist “flashover” and associated misfire

For further information on these and all of the other exciting and innovative products from Altronic, please contact your local Altronic Distributor, Dealer or Regional Manager. Their contact information can be found on the web at www.altronicinc.com.



EZRail® Modular Ignition Rail System Features & Benefits

Modular Ignition Rail System for Natural Gas Engines

EZRail® is a comprehensive line of modular ignition wiring and coil-mounting systems. Factory-built in Altronic's Ohio facility, EZRail® systems are thoroughly tested to ensure maximum reliability and performance.

Operational and functional benefits include:

- Complete wiring/mounting system from the ignition unit to the ignition coils. Eliminates hours of wire and conduit cutting in the field. Guarantees against skinned insulation due to long conduit pulls.
- Universal design takes advantage of standard cables, wiring rails and integral/flange or off-mounted coils (shielded or unshielded). EZRail® systems can be cost-effectively configured for service in any hazardous or non-hazardous area. Optional bolt-on coil mounting rails give users a robust and reliable means of mounting ignition coils without compromising the integrity of the wiring rail or the ability of the rail to be serviced if necessary.
- Flexible and upgradable. If coil types are changed, e.g., from unshielded to shielded or integral, the same wiring rail can be used without modification. The same is true if the coil mounting rail is added later. Competing systems require a completely new, entirely different rail assembly.
- Premium construction materials. No “pop rivets” or foam here — only high-quality aluminum extrusions, sealed junction boxes, and military-style connectors and harnesses are used. To insure long-term service, all connector back shells are potted and strain-relieved.
- Fully serviceable. An ignition wiring rail is too critical to be a “disposable” item. Incorporating standard Altronic ignition components into the design, including the primary and secondary cables and leads, allows for quick, cost-effective repair and service in the field. In the unlikely event that the rail itself requires service (or if on-engine mechanical work is required), the EZRail® system can be easily disconnected, removed, and re-installed.
- Service makes the difference. EZRail® is backed by the most capable and experienced gas engine accessory product distribution system in the world. At the end of the day, good product performance relies upon solid field service. Altronic Distributors and Dealers are unparalleled in their ability to deliver timely, high-quality technical services for all products, including the EZRail system.



Shown with optional coil mounting rail

EZRail® System Components for High-Speed Engines

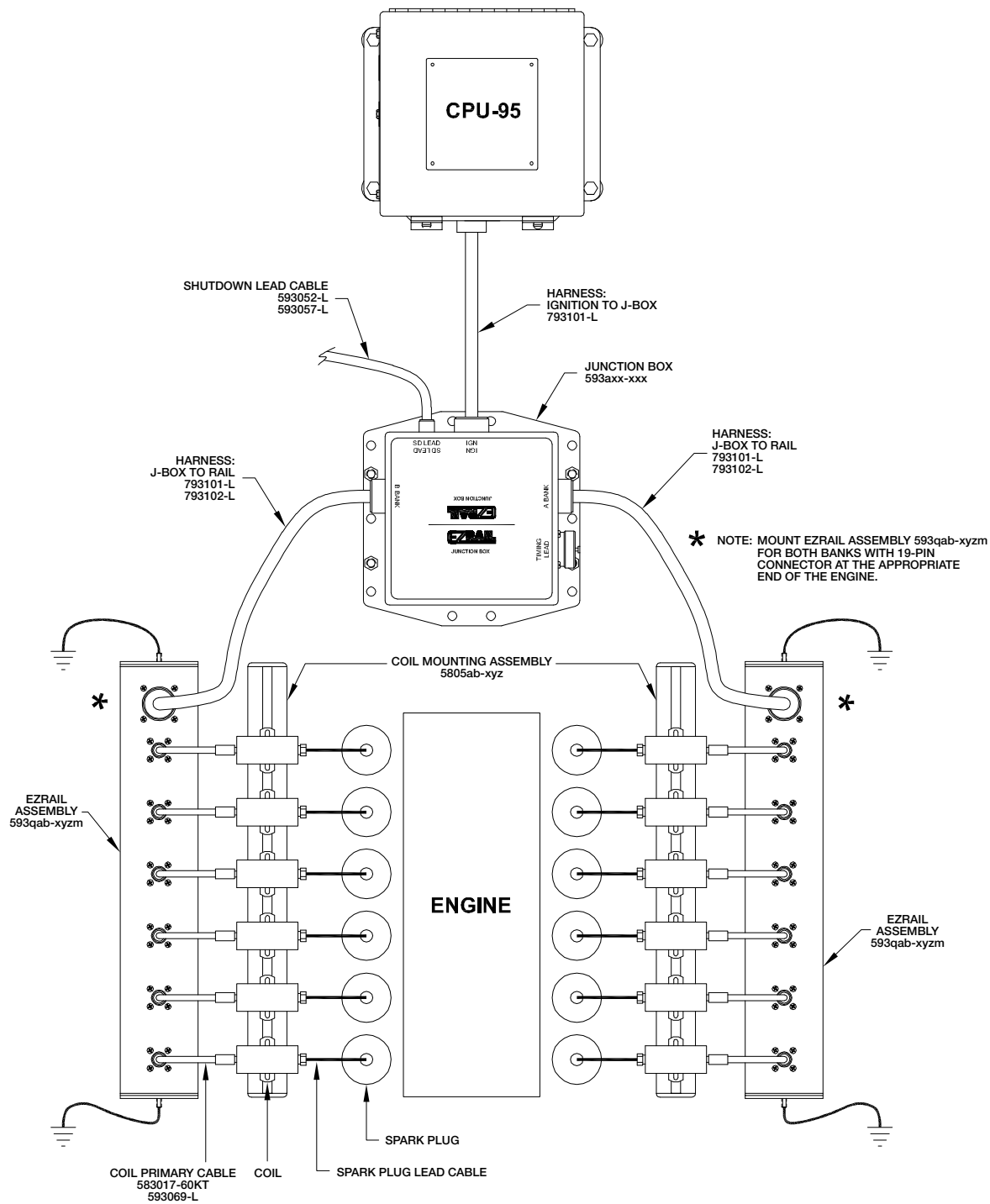

Refer to Form
EZRail AL
for detailed
information.

EZRail® System Components for Integral Engines

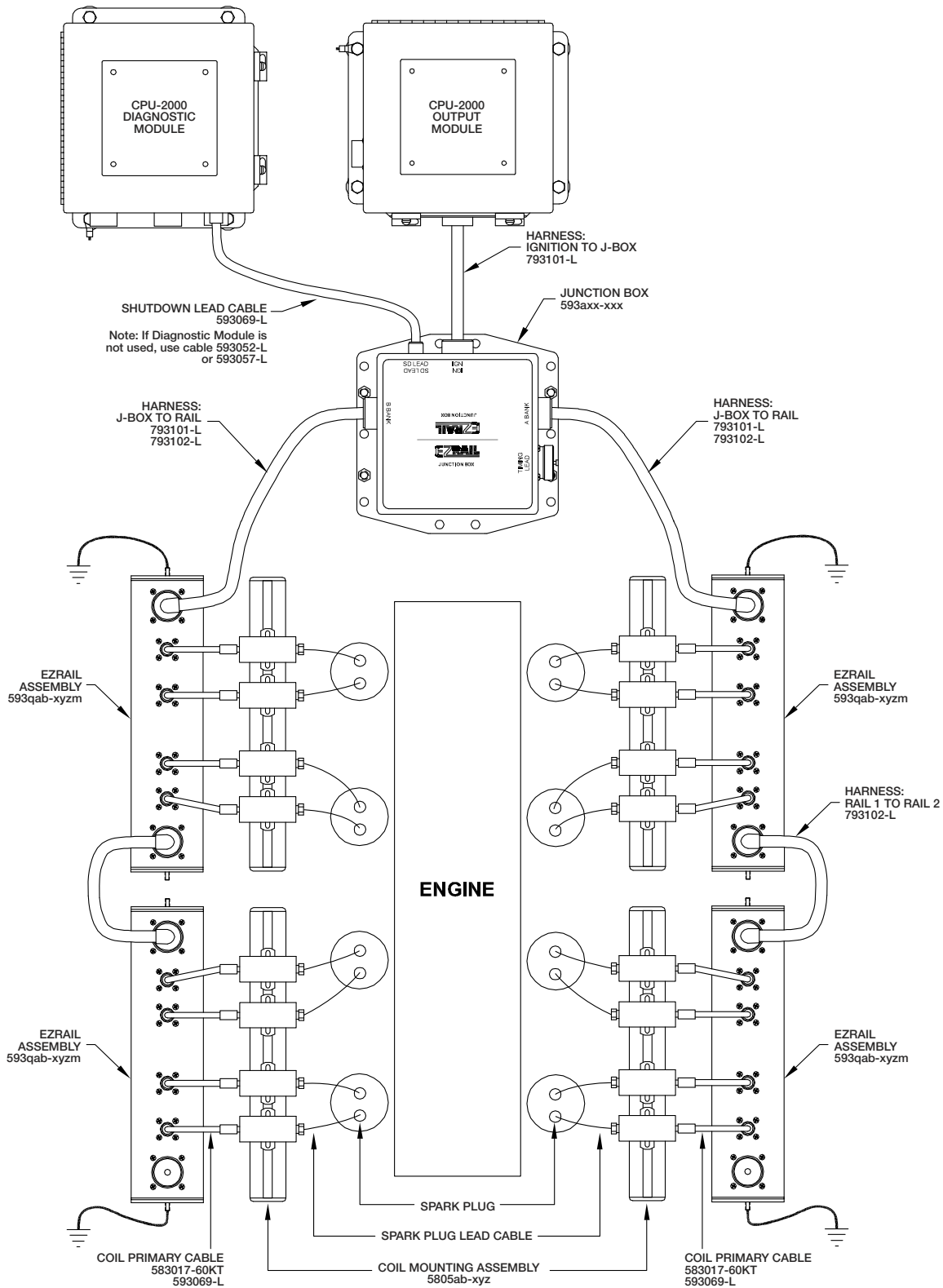

Refer to Form
 EZRail AL
 for detailed
 information.

Altronic Spark Plug Leads Features and Benefits

Altronic offers a complete line of ignition spark plug leads for use on standard applications as well as for applications operating in areas requiring Class I, Division 2, Group D compliance. These high quality industrial leads are available with a wide variety of primary and secondary terminations for use with unshielded and shielded coils as well as standard and shielded spark plugs.

FLASHGUARD® secondary lead assemblies, which incorporate an integral 5,000 ohm resistor and tight-fitting silicone or Teflon boots, provide longer spark plug life and excellent durability. Engine-related digital controls and instrumentation also benefit from the reduction in RFI (electrical “noise”) brought about by the built-in resistor. FLASHGUARD® spark plug leads are also available with special extensions for deep well applications.

FLASHGUARD® Spark Plug Boot Design and Materials

The basic function of a spark plug boot is to prevent flash over. Altronic spark plug boots are available in a number of tight-fitting silicone configurations as well as in Teflon with integral, flashover-resistant O-rings.

Altronic silicone boots provide exceptional sealing to the plug. This raises the “flashover” voltage of the assembly and helps insure that the likely place for the discharge of electrical energy is not along the outside of the insulator but at the spark plug electrodes. Silicone boots are ideal for most standard, rich-burn applications.*

Teflon boot construction is preferable for severe temperature applications, such as those operating with precombustion chambers. Since lean burn applications often require over 20,000 volts to initiate an arc between the center and ground electrodes, the integral O-rings standard on the Altronic Teflon boots help to suppress flashover on the outside of the spark plug insulator.

- High quality, corrosion-resistant components for heavy duty industrial applications
- Wide variety of ignition coil and spark plug termination options
- Shielded and unshielded configurations available
- Boot and lead assemblies, featuring integral 5,000 ohm resistor and high quality boot construction, improve flashover resistance, plug performance, and reduce RFI

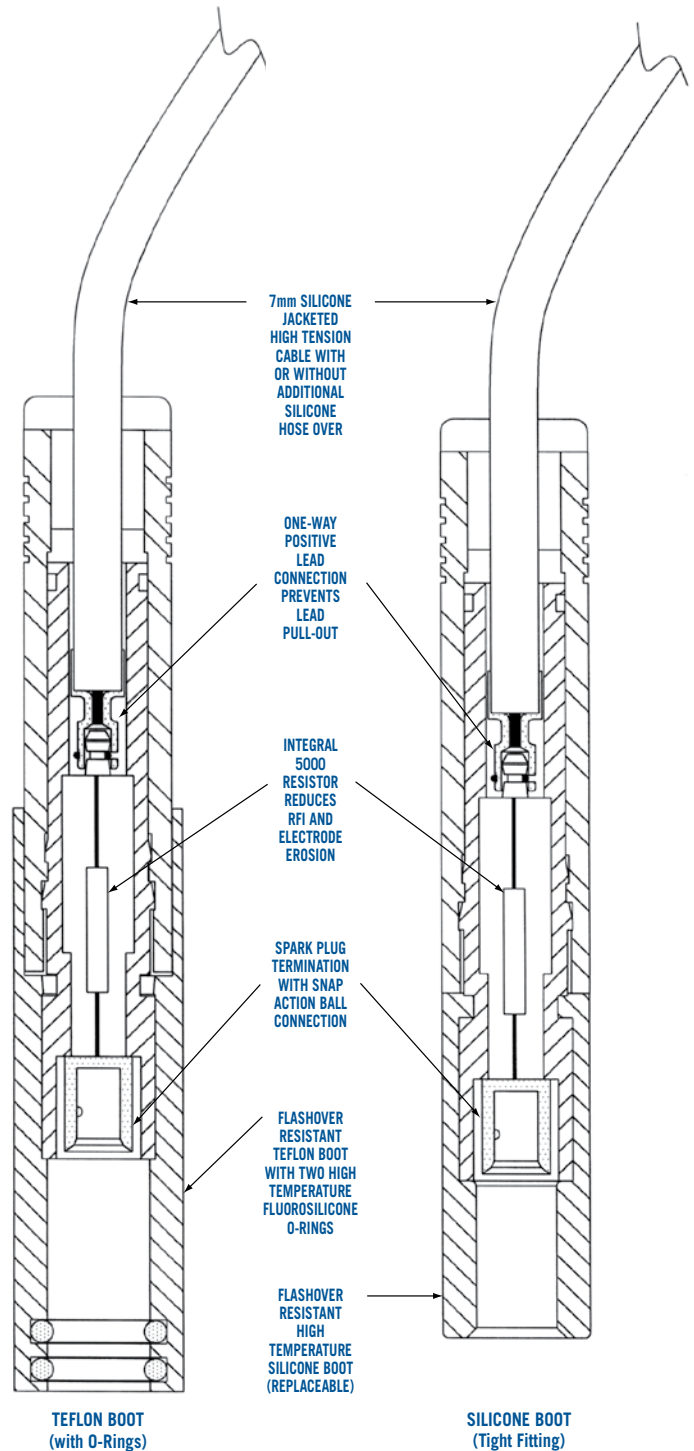

**NOTE: Prior to use, silicone boots should be lubricated with a high-temperature, high-dielectric compound, such as ChristoLube MCG147 or Permatex Dielectric Tune-up Grease.*

Universal FLASHGUARD® Spark Plug Leads & Parts Breakdown

Universal FLASHGUARD® Spark Plug Leads

Universal lead assemblies can be made into specific types by adding one of three optional spark plug boots and one of three optional coil termination packages,

Spark Plug	Coil Type	Description	Item No.	Part No.
All	All	Lead Assembly 4" extension (complete leads on pg. 9)	1	593200-30
All	All	Lead Assembly 9" extension (complete leads on pg. 9)	1	593250-35

Spark Plug End (choose one)

Unshielded Spark Plug	Description	Item No.	Qty.	Part No.
14mm	Spark plug boot, silicone	2a	1	504235-1
	Spark plug boot, Teflon (1)	2b	1	504276 (1)
	Spark plug boot, Teflon (3)	2c	1	504280 (3)
	Spark plug boot, Teflon (4)	2b	1	504313 (4)
18mm, 7/8"-18	Spark plug boot, silicone	2a	1	504235-2
	Spark plug boot, Teflon (3)	2b	1	504280 (3)
	Spark plug boot, Teflon (2)	2c	1	504254 (2)

- (1) Boot designed to fit Champion RC78PYP and RX85PYP spark plugs only
- (2) Long boot only fits spark plugs with an exposed insulator of 1.5" or longer
- (3) Short boot for use with Champion spark plugs with an exposed insulator of less than 1.5"
- (4) Short boot for use with Altronic 14mm spark plugs

Ignition Coil End (choose one)

Coil Type	Description	Item No.	Qty.	Part No.
Unshielded	Coil terminal, 180 Coil boot, 180	3a	1	504040 502122
	Coil terminal, 90 Coil boot, 90			504207 504180
Shielded	Coil secondary kit	3b	1	510480
	Coil kit with silicone hose	3c	1	510714

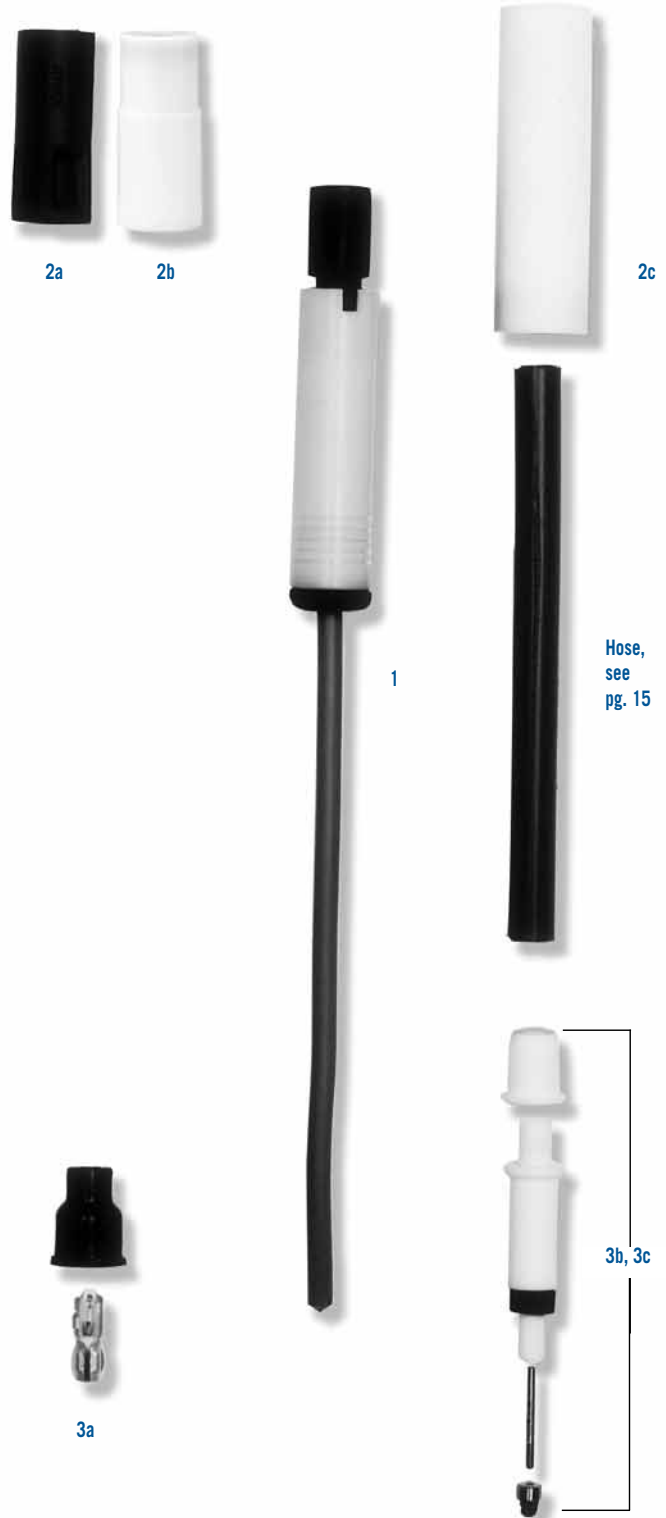

Assembled FLASHGUARD® Spark Plug Leads



FLASHGUARD® Spark Plug Leads

Extension Length	Coil End	Plug Type	Plug Boot	Part No.	Lengths (l)
4"	Unshielded	14mm	Silicone	593201-L	12", 16", 18", 20", 24"
		18mm, 7/8"	Silicone	593202-L	
		18mm, 7/8"	Teflon 1	593211-L	
		18mm, 7/8"	Teflon 2	593212-L	
	Shielded	14mm	Silicone	593203-L	12", 16", 18", 20", 24"
		18mm, 7/8"	Silicone	593204-L	
		18mm, 7/8"	Teflon 1	593213-L	
		18mm, 7/8"	Teflon 2	593214-L	
	Shielded with hose	14mm	Silicone	593205-L	12", 16", 18", 20", 24"
		18mm, 7/8"	Silicone	593206-L	
		18mm, 7/8"	Teflon 1	593215-L	
		18mm, 7/8"	Teflon 2	593216-L	
9"	Unshielded	18mm, 7/8"	Silicone	593251-L	17", 24", 29", 33", 35"
		18mm, 7/8"	Teflon 1	593259-L	
		18mm, 7/8"	Teflon 2	593252-L	
	Shielded	18mm, 7/8"	Silicone	593253-L	17", 24", 29", 33", 35"
		18mm, 7/8"	Teflon 1	593255-L	
		18mm, 7/8"	Teflon 2	593254-L	
	Shielded with hose	18mm, 7/8"	Silicone	593260-L	17", 24", 29", 33", 35"
		18mm, 7/8"	Teflon 1	593256-L	
		18mm, 7/8"	Teflon 2	593257-L	

Teflon 1: P/N 504180 boot — use with plug insulator length of less than 1.5"
 Teflon 2: P/N 504254 boot — use with plug insulator length of 1.5" or longer

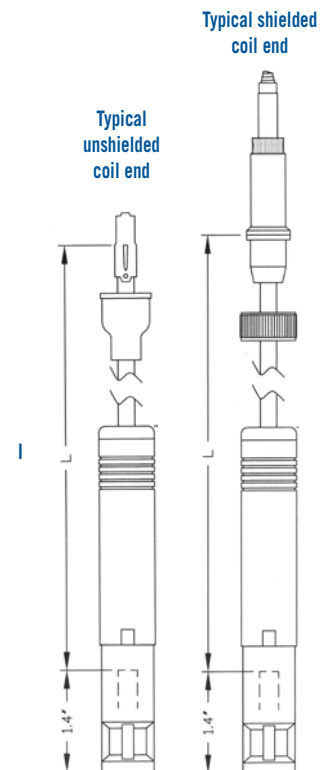

NOTE: Length "L" for FLASHGUARD® leads is measured from spark plug termination to coil termination, including extension length.



FLASHGUARD® Spark Plug Leads

The Altronic FLASHGUARD® spark plug lead for the Caterpillar G342, G379, G398, and G399 engines is for use with unshielded ignition coils and uses a 5,000 ohm resistor lead assembly in conjunction with a tight-fitting 14mm spark plug boot.

Part Number	Length
593207-18	18"
593209-30	30" universal version

Other Altronic Spark Plug Leads



Standard Spark Plug Leads for Unshielded Spark Plug, Unshielded Coil

Non-resistor lead uses a standard silicone spark plug boot and is for use with unshielded ignition coils and unshielded spark plugs.

Part Number	Lengths "L"
593028-L	13", 17", 18", 21", 24"



Standard Spark Plug Leads for Unshielded Spark Plug, Shielded Altronic Coil

For applications operating with shielded Altronic ignition coils and unshielded spark plugs, Altronic offers a lead with a shielded termination (coil side) and a silicone spark plug boot. It is available in a variety of lengths.

Part Number	Lengths "L"
593005-L	12", 16", 18", 22"



CSA-Certified Shielded Spark Plug Leads for Class I, Division 2, Group D Hazardous Areas

In order to comply with requirements for Class I, Division 2, Group D hazardous areas, Altronic manufactures a stainless steel-jacketed spark plug lead with a Teflon inner liner and shielded terminations. This lead is compatible with shielded Altronic ignition coils and shielded (aircraft-style) spark plugs with 3/4"-20 connections.

Part Number	Spark Plug Well	Spark Plug End	Coil End	Lengths "L"
593020-L	1"	180°	180°	10", 13", 16", 18", 24", 30"
593030-L	2"			



CSA-Certified Safe-T-Lead™ Spark Plug Leads for Class I, Division 2, Group D Hazardous Areas

The Altronic Safe-T-Lead™ is a patented spark plug lead designed for use in Division 2 hazardous area applications. Using a proprietary, semi-conductive jacket over the high-tension cable instead of the traditional stainless steel braid, the Division 2 certified Safe-T-Lead™ enables the operator to use conventional troubleshooting tools such as timing lights, neon firing indicators, and scope probes. The reduction in capacitive loading, brought about by the elimination of the metallic jacket, also contributes to an increase of available voltage at the spark plug.

Part Number	Spark Plug Well	Spark Plug End	Coil End	Lengths "L"
593121-L	1"	180°	180°	14", 18", 22"
593122-L	1"	180°	90°	14", 18", 22"
593123-L	1"	90°	180°	14", 18", 22"
593131-L	2"	180°	180°	14", 18", 22"
593132-L	2"	180°	90°	14", 18", 22"
593133-L	2"	90°	180°	8", 14", 18", 22"
593134-L	2"	90°	90°	14", 19"

Altronic FLASHGUARD® Industrial Spark Plugs

FLASHGUARD® industrial spark plugs are designed to increase effective spark plug service life by reducing flashover and electrode erosion while optimizing combustion and minimizing radio frequency interference (RFI).

Modern spark-ignited gas engines, particularly high performance, lean-burn configurations, demand that increasingly higher voltage levels be delivered to the spark plug to insure a strong spark at the plug electrodes. The FLASHGUARD® family of products meets the industry need for high-quality secondary leads and spark plugs to complement Altronic's high performance digital ignition systems, such as the CD200, CD200D, DISN, CPU-95, and CPU-2000.

The ignition system is only as good as its weakest link—the delivery of the high voltage spark energy between the ignition coil and spark plug electrodes. FLASHGUARD® products provide an effective solution, even in demanding applications, and offer engine users reduced operating and fuel costs, as well as less frequent spark plug changes. Whether in search of longer spark plug life in conventional engines, or reliable combustion in lean-burn applications, the features and capabilities of the FLASHGUARD® secondary leads and spark plugs make them a logical choice for use

on any industrial engine application.

- Double-glazed alumina ceramic insulators with grooved profiles resist flashover up to 40,000 volts
- A variety of electrode configurations and reaches to precisely match the spark plug to the application
- FLASHGUARD® spark plugs feature a proprietary spark plug nose cone designed to minimize internal flashover-related misfire – often referred to as “cone discharge”
- Reduced radio frequency interference (RFI) and electrode erosion due to the integration of a high ohmic internal resistor
- Electrode designs and large internal nose cone clearances allow for superior scavenging and circulation of the combustible mixture between the electrodes which ultimately leads to improved combustion stability
- Most Altronic FLASHGUARD® spark plugs are constructed for use with the tight-fitting, Altronic FLASHGUARD® secondary leads for further reduction in flashover and improved spark plug service life

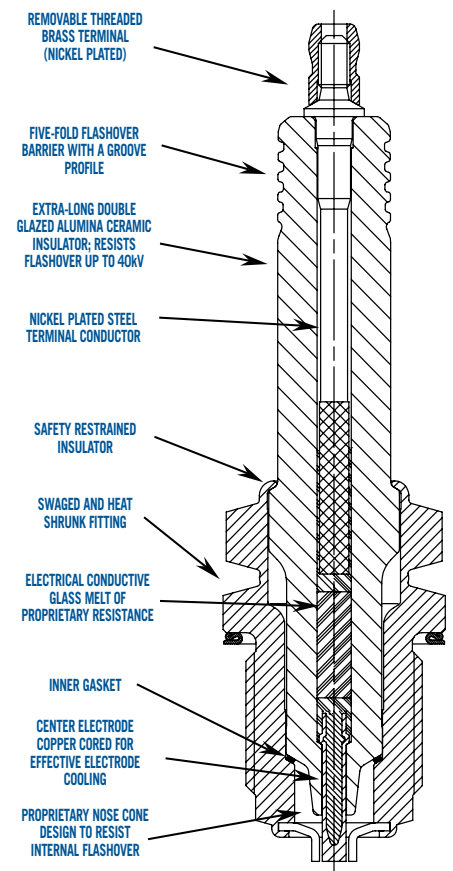

FLASHGUARD® Industrial Spark Plugs Types and Configurations

FLASHGUARD® Massive Electrode Spark Plugs

Developed for use on medium and large-bore natural gas-fueled engines, these plugs are suitable for stoichiometric and lean-burn applications (open-chamber or pre-chamber). This design is particularly helpful for applications in which air/fuel mixing and scavenging is irregular or voltage demand (due to lean operation or high compression ratio) is high. The massive designs are available in both 18mm and 7/8"-18 thread sizes and with various reaches.

FLASHGUARD® Precious Metal Spark Plugs

Lean-burn engines, which can require a spark in excess of 30,000 volts, and expose the spark plug to elevated temperatures, need more frequent spark plug maintenance and replacement. Due to their intrinsically high resistance to erosion, precious-metal Altronic spark plugs offer substantially improved life and performance. Altronic gold palladium (G) and platinum (DP) designs should be used only in open-chamber engines. Iridium-platinum plugs (IP) may be used in both open and pre-combustion chamber engines. Both types provide very long operating life in conventional engines.

G Series Gold Palladium Electrodes

The most economical precious metal spark plug offered. Gives extended life compared to plain nickel electrode spark plugs.

DP Series Two-Wire Platinum Electrodes

Moderate price and enhanced performance for open-chamber, lean-burn applications. DP-series plugs are available in 14mm, 18mm, and 7/8"-18 sizes and unshielded and integral versions.

IP Series Iridium-Platinum Electrodes

The L1863IP model fits many popular engines such as the Caterpillar G3500, G3600, and Waukesha AT and VHP-GL-series engines. The iridium center electrode assures long life in open-chamber or pre-chamber lean-burn engines.

Which spark plug electrode type is right for my application?

Electrode Type	Cost Factor	Conventional Engine	Lean-Burn Engine
Massive (-B)	Lowest	Good service life	Short service life
Gold Palladium (-G)	Moderate	Long service life	Open-chamber engine only; fair service life
Platinum (-DP)	Medium	Very long service life	Open-chamber engine only; good service life
Iridium-Platinum (-IP)	Highest	Very long service life	Open or pre-chamber engines; best service life

Spark Plug Types

Thread Size	Thread Reach	Hex Size	Part No.	Description
14mm	1/2"	13/16"	J1443G J1443DP	Unshielded, gold palladium Unshielded, platinum
	3/4"	13/16"	J1463G J1463DP	Unshielded, gold palladium Unshielded, platinum
		7/8"	N1463DP	Integral, platinum
18mm	1/2"	7/8"	L1843B L1843IP N1843B	Unshielded, massive nickel Unshielded, iridium-platinum Integral, massive nickel
	13/16"	7/8"	L1863B L1863DP L1863IP N1863DP	Unshielded, massive nickel Unshielded, platinum Unshielded, iridium-platinum Integral, platinum
7/8"-18	5/8"	15/16"	L2252B L2252DP L2252IP	Unshielded, massive nickel Unshielded, platinum Unshielded, iridium-platinum
	0.86"	15/16"	L2272B	Unshielded, massive nickel
	1"	15/16"	L2282B L2282IP	Unshielded, massive nickel Unshielded, iridium-platinum

- Standard gap is .012" (0.30mm) for L1863IP and .014" (0.35mm) for all other types
- Recommended installation torque is 24 ft-lbs. for 14mm, 35 ft-lbs. for 18mm, 50 ft-lbs. for 7/8"-18 type
- "B" suffix plug replaces former "A" suffix model; "DP" suffix plug replaces former "P" suffix model

Spark Plug Part Number Designation

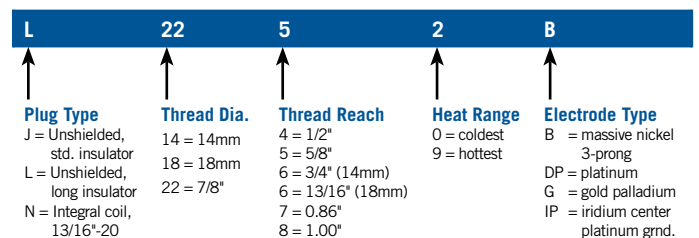

FLASHGUARD® Industrial Spark Plugs Application List

FLASHGUARD® Spark Plug Leads

Manufacturer/Model	Nickel Electrodes	Precious Metal Electrodes
AJAX LE models (precombustion chamber) All other models	L2252B L2252B	L2252IP L2252DP, L2252IP
CATERPILLAR G342, G379, G389, G399 3300 series – 1/2" reach 3300 series – 3/4" reach 3400 series 3500 series* 3600 series	— — — — L1863B* L1863B	J1443DP, J1443G J1443DP, J1443G J1463DP, J1463G, N1463DP J1463DP, J1463G, N1463DP L1863DP*, L1863IP* L1863IP
CLARK Models with precombustion chamber All other models	L2252B L2252B	L2252IP L2252DP, L2252IP
COOPER-BESSEMER 5/8" reach, precombustion chamber 5/8" reach, open chamber 1" reach, precombustion chamber 1" reach, open chamber	L2252B L2252B L2282B, L2272B L2282B, L2272B	L2252IP L2252DP, L2252IP L2282IP L2282IP
DELAVAL HV, HVA series	L2282B	L2282IP
INGERSOLL RAND Models with precombustion chamber All models replacing RW83F	L2282B L2272B	L2282IP L2282IP
MEP MEP – 6, 8, 10, 12	L1843B, N1843B	L1483IP
SUPERIOR 2400 series G825, GT825, GTL, SGT – 18mm plugs G825, GT825, GTL, SGT – 7/8"-18 plugs	L1863B L1843B, N1843B L2252B	L1863IP L1843IP L2252DP, L2252IP
WAUKESHA AT series – 1/2" reach heads AT series – 13/16" reach heads VGF series VGF series (shielded) VHP-G, VHP-GSI series VHP-GL series – 1/2" reach heads VHP-GL series – 13/16" reach heads	L1843B, N1843B L1863B L1863B — L1843B, N1843B L1843B, N1843B L1863B	L1843IP L1863IP L1863DP/L1863IP N1863DP L1843IP L1843IP L1863IP
WORTHINGTON All models	L2252B	L2252DP, L2252IP

* Requires longer spark plug terminal 510726 when used with Caterpillar EIS ignition system
Note: "B" suffix plug replaces former "A" suffix model; "DP" suffix plug replaces former "P" suffix model

SHELL TYPES

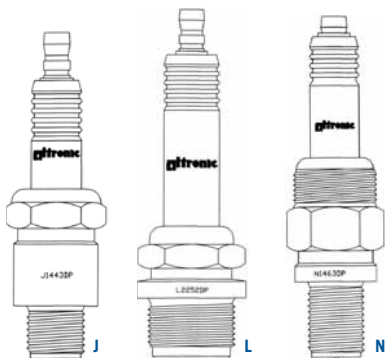

ELECTRODE TYPES

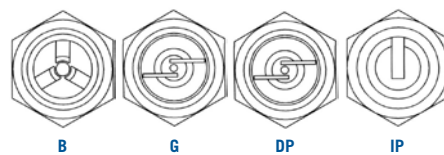

FLASHGUARD® Spark Plug & Spark Plug Lead Accessories

FLASHGUARD® Spark Plug Replacement Parts

Thread Size	Spark Plug Gasket	Spark Plug Terminal Nut
14mm	510749	510720
18mm	510721	510720 510726*
7/8"-18	510722	510720

* 510726 terminal required when used with Cat EIS ignition



FLASHGUARD® Installation & Maintenance Tools

FLASHGUARD® Spark Plug Installation and Removal Sockets

These high quality, industrial spark plug sockets, available in 7/8" and 15/16" hex sizes, are ideal for performing maintenance on FLASHGUARD® series spark plugs. A spring-loaded design built into the socket "captures" the spark plug shell and assists in removing the plug from the head and well.



FLASHGUARD® Massive Electrode Spark Plug Gapping Tool

Designed exclusively for use with FLASHGUARD® spark plugs, these unique tools apply uniform, incremental pressure to the ground electrodes when they require re-gapping. This method of gapping minimizes the risk of damaging the ceramic insulator or distorting the electrode configuration. Tools are available in 18mm and 7/8"-18 thread sizes.



Thread Size	Spark Plug Gasket	Spark Plug Terminal Nut
18mm	506010	506012
7/8"-18	506011	506013

Replacement Spark Plug Boots, FLASHGUARD® and Standard

Part Number	Material	Application
501151	Silicone	593005, 593028
504235-1	Silicone	593201, 593203, 593205, 593207
504235-2	Silicone	593202, 593204, 593206, 593251, 593253
504254	Teflon with O-Ring 504253 (qty. 2)	18mm and 7/8"-18 spark plugs with an exposed insulator length of 1.5" or longer
504276	Teflon with O-Ring 504275	14mm spark plugs with 0.41" dia. insulator Champion RC78PYP and RX85PYP
504280	Teflon with O-Ring 504281	18mm and 7/8"-18 spark plugs with an exposed insulator length of less than 1.5"

FLASHGUARD® Spark Plug & Spark Plug Lead Accessories

Altronic Spark Plug Lead Wire

503186-100 Standard Copper Conductor

503369-100 Stainless Steel Conductor

Available in 100 foot spools, Altronic spark plug wire has been specifically designed for industrial gas engine applications. This high quality wire comes with a firm silicone jacket and is available in both standard tinned copper and stainless steel versions. These cables are capable of withstanding ambient temperatures to 500 degrees F. and are used in various Altronic standard and FLASHGUARD® spark plug leads.



Altronic Spark Plug Lead Hose — 503328-100

Altronic spark plug lead hose is available for those applications requiring an extra measure of mechanical and environmental protection. It assists in preventing lead abrasion caused by repeated contact with a vibrating surface such as a cylinder head. This 5/16" silicone hose also reduces deterioration due to environmental effects such as rain and intense sunlight. Altronic spark plug lead hose is available in 100 foot spools.



Altronic Shielded Coil Secondary Lead Termination Kits

Item	Description	Qty.	Unshielded Lead	Unshielded w/silicone hose	Shielded Lead
1-6	Kit		510480	510714	510480-S
1	Nut, 3/4"-20	1	504088	*	None
2	Ferrule	1	504098	None	None
3	Stud	1	510473	510473	510473
4	Insulator	1	510695	*	510472
5	Washer	1	510493	None	510493
6	Spring Unit	1	510474	510474	510474

* Available only in kit

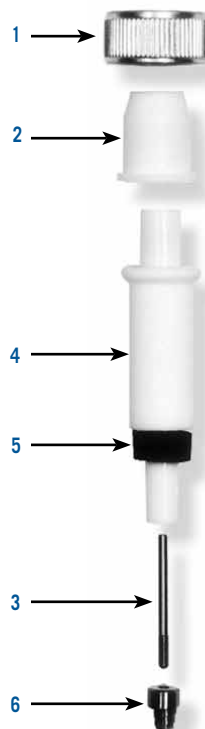

The HOERBIGER Group

HOERBIGER Compression Technology is a business unit of HOERBIGER Holding AG, Zug / Switzerland. HOERBIGER is active throughout the world as a leading player in the fields of compression technology, automation technology and drive technology. Its 6,400 employees achieve sales of around 1 billion Euro. The focal points of its business activities include key components and services for compressors, gas engines and turbomachines, hydraulic systems and piezo technology for vehicles and machine tools, as well as components and systems for shift and clutch operations in vehicle drive trains of all kinds. Through innovations in attractive technological niche markets, the HOERBIGER Group sets standards and delivers cutting-edge solutions for the benefit of its customers.



ALTRONIC INC
712 Trumbull Avenue
Girard, Ohio 44420 USA
P: 330-545-4045
F: 330-545-9005

ALTRONIC EUROPE BV
De Tienden 50A
5674 TB Nuenen
The Netherlands
P: 011-31-40-2906270
F: 011-31-40-2838990

Form AIA-C 9-09